



**FUA01 монтаж секційних воріт з пружинами розтягу**

**FUA02 монтаж секційних воріт з притолокою від**

**150мм до 220мм**

**FUA02 монтаж секційних воріт низький підйом**

## General information

This is the installation manual for the HYBRID 02, RSD01, RSD02 LOW LIFT.

The manual contains important information for the installation, safe operation and maintenance of the doors.

Please, keep this manual.

In case of any difficulties or misunderstanding during the installation of the doors, please contact your technical support service (see «Technical support service»).

It's strongly forbidden to use and install any parts that are not the original parts of the doors supplied by the manufacturer. Such parts may be installed only with the written confirmation of the manufacturer.

**Attention!** Keep children away during the installation of the doors. Some parts can injure them.

For the installation of the operator, please read carefully its specific installation manual and follow all the instruction to prevent any damages to the doors and your house.

Before you start to install the doors, please, check that the opening has been prepared according to the supplied technical data.

The opening of the door must be free of any obstacles.

## General installation conditions

Installation team recommendations:

The installation of the doors can be done by 1 person. However, the manufacturer recommends the installation to be carried out by 2 persons including 1 certified electrician.

Average installation time is 3 hour.

Before starting the installation, please make sure, that you have all the tooling needed for it (see page 15).

## Installation responsibility

Due to the impossibility to control the installation process

by the manufacturer, the installer is held responsible and must prevent any possible risks. He must ensure good quality of fixation to the walls of building.

In any case the manufacturer of thae doors will not bear responsibility for possible financial loss, property damages, injuries, or any other possible risks that may appear as the result of the installation.

## Operation

The doors should move up and down without difficulty.

The doors should be balanced.

Manual opening or closing of the doors must be done only using the provided handle. Attention! Never put your fingers between the panels, neither from outside nor from inside the building.

Lock the door using special latch or mechanical lock.

The parts of the doors should be well lubricated.

Keep children and animals out of the doors operation area.

Do not put any obstacles inside the opening and doors track path.

## Technical problems

In case of any problems with the product, please call the technical support service.















## Technical support service

You can find the information about the hot line for the technical support in the purchasing contract you have got from your vendor.

Please note, that the manufacturer has the right to change the technical specification of the product without notifying the user.

Thank you very much for purchasing our sectional doors.

## SYMBOLE

	gate element		incorrect installation		note		installation with the aluminum frame
	fastening element		correct installation		information in mounting card		optional
	set level		apply force		required amount of spring turns		
	unpack		dismantling		drill		

Ця інструкція по монтажу секційних воріт FUA02, FUA01. Інструкція включає важливу інформацію по установці, безпечному використанню та обслуговуванню воріт. Прохання дотримуватись цієї інструкції. У випадку будь-яких ускладнень або непорозуміння під час установки воріт, просимо зв'язуватися з службою технічної підтримки або персональним менеджером. Суворо заборонено використовувати і встановлювати будь-які деталі, які не являються комплектацією воріт, що поставляються виробником. Такі комплектуючі можуть бути установлені тільки після письмового підтвердження від виробника. Увага! Тримайте дітей подалі під час установки воріт. Деякі деталі можуть їх поранити. Для установки приводів, читайте, будь ласка, уважно відповідну інструкцію і дотримуйтесь її, щоб запобігти будь-яким пошкодженням воріт та вашої оселі. Перед тим, як ви почнете встановлювати ворота, перевірте, щоб проєм був підготовлений згідно технічних вимог постачальника. Відкриття воріт повинно здійснюватися вільно без перешкод. Загальні рекомендації по установці. Рекомендації для монтажників: установка воріт може бути виконана однією людиною. Але, виробник рекомендує забезпечити установку двома особами, включаючи сертифікованого електрика. Середній час для установки складає 3 години. Перед тим, як почати установку, перевірте наявність комплектації.















#### Експлуатація.

- Ворота повинні рухатися вгору і вниз без ускладнень.
- Ворота повинні бути збалансовані.
- Ручне відкриття або закриття воріт повинно здійснюватись тільки за допомогою ручки. Увага!

Ніколи не засовуйте пальці між панелями, ні із середини, ні ззовні будівлі. Зачиняйте ворота за допомогою спеціального фіксатора або механічного замка. Комплектуючі для воріт повинні бути добре змащеними. Тримайте дітей та тварин за межами площі руху воріт. Не завдавайте перешкод при відкритті і русі воріт. Зверніть будь-ласка увагу на те, що виробник має право змінити технічну характеристику продукції, не повідомивши про це клієнтів.

Дякуємо вам за те, що придбали наші секційні ворота.

#### SYMBOLS

	gate element		incorrect installation		note		installation with the aluminum frame
	fastening element		correct installation		information in mounting card		optional
	set level		apply force		required amount of spring turns		
	unpack		dismantling		drill		

## ИСТРУМЕНТ

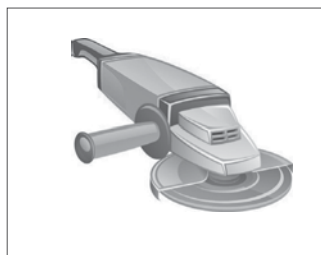
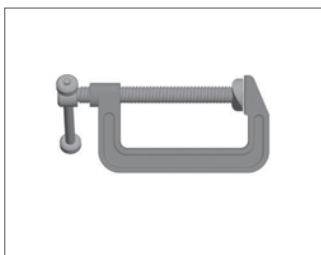
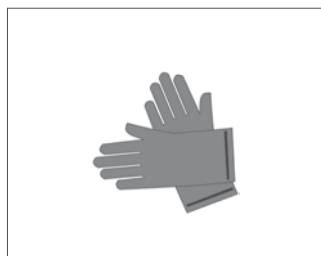
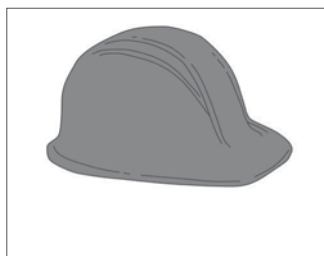
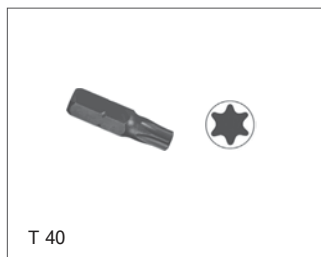
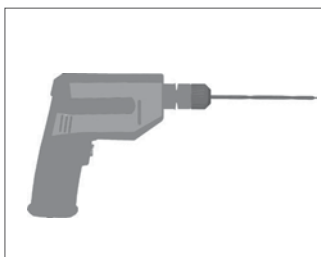
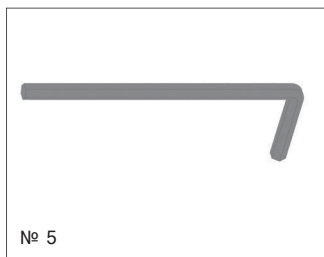
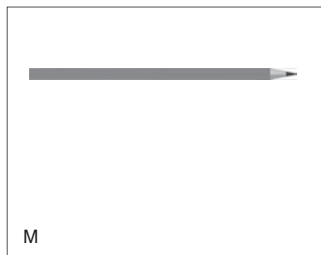
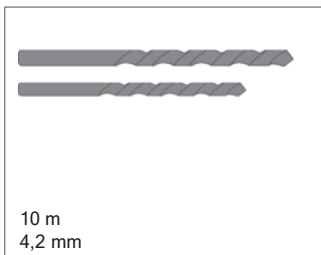
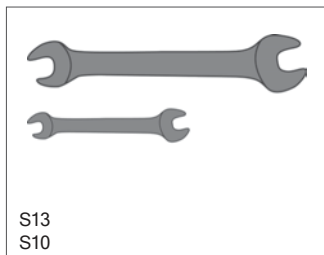
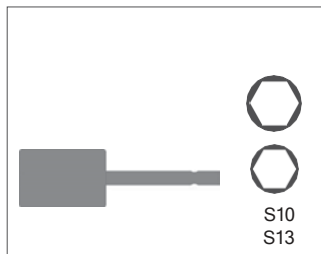
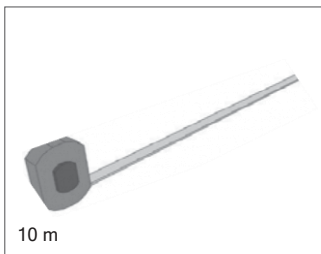
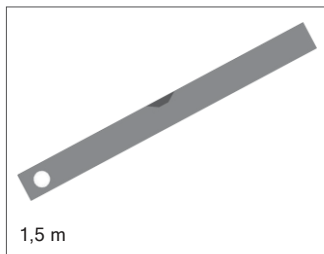

# СЕКЦІЙНІ ВОРОТА FUA01 ПРУЖИНИ РОЗТЯГУ

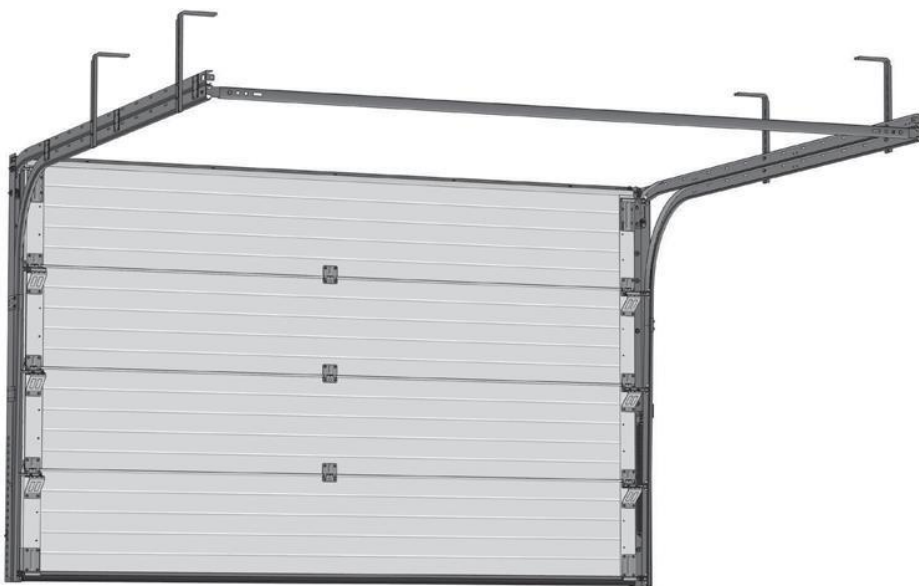

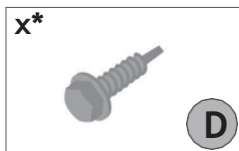
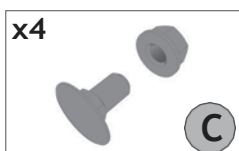
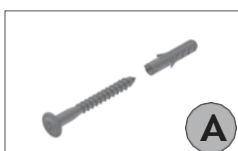
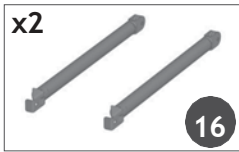
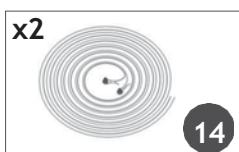
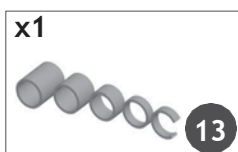
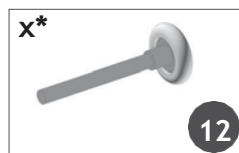
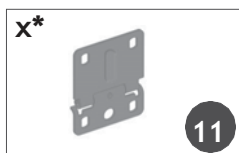
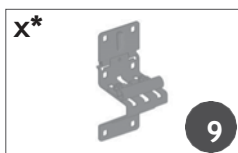
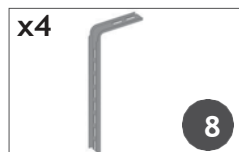
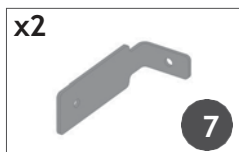
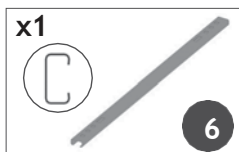
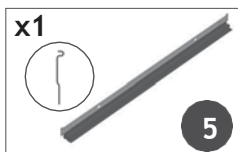
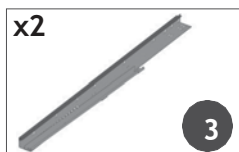
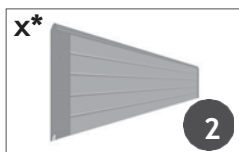
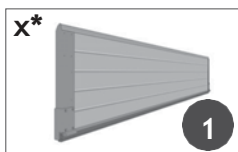

8 × 70 mm

M 6 × 16 mm

M 6 × 16 mm

6,3 × 32 mm

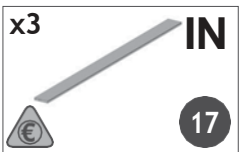
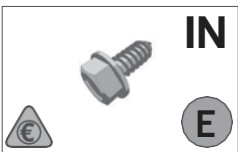

6,3 × 16 mm

x\* – розраховується індивідуально

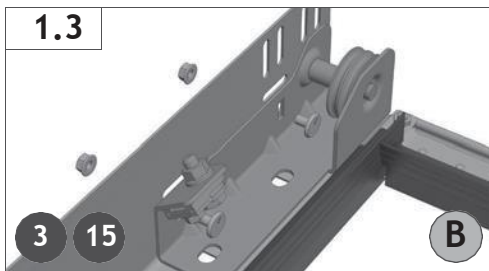
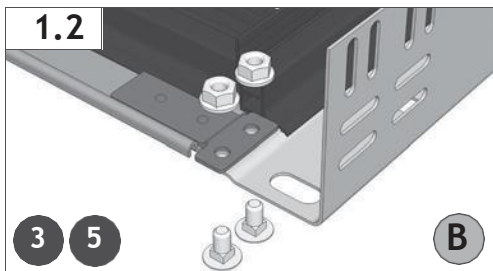
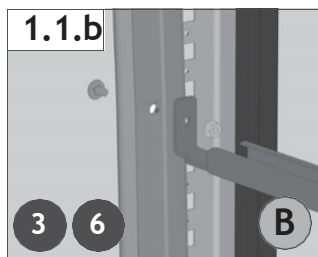
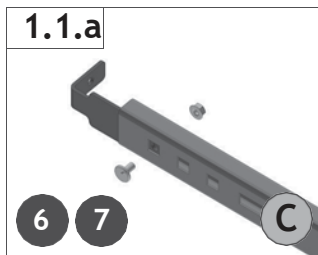
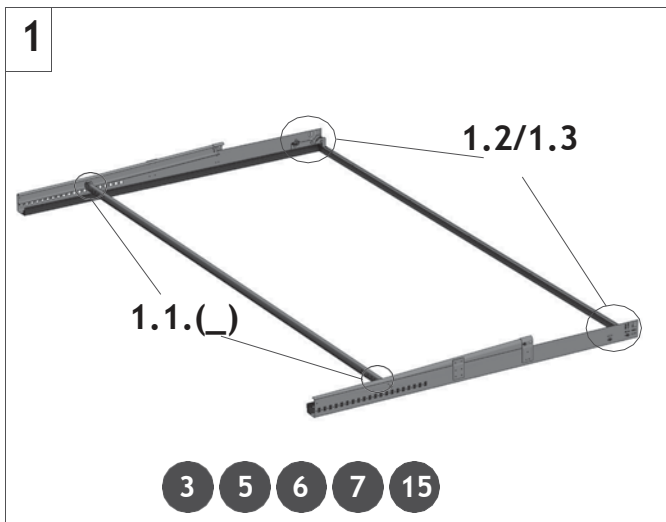
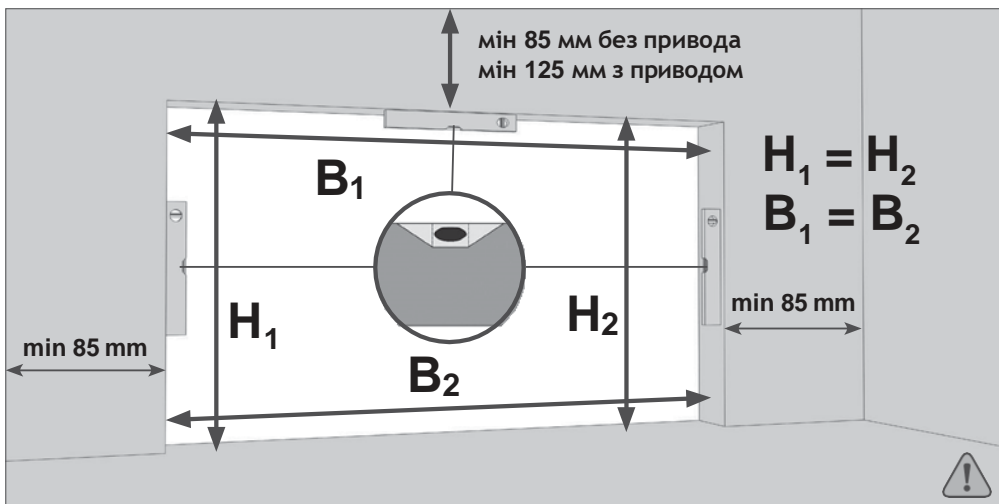

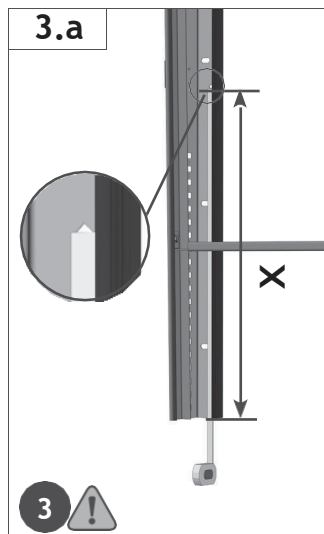
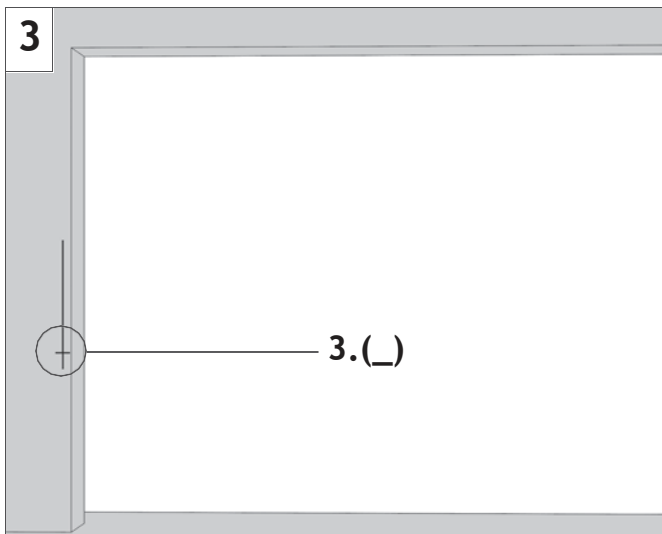
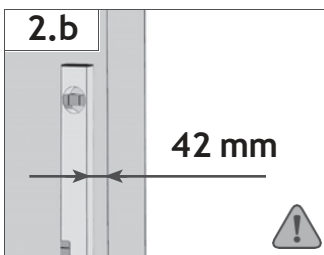
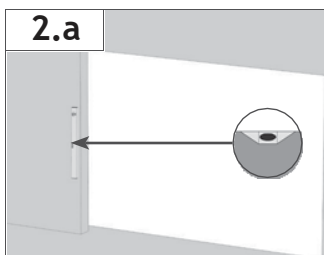
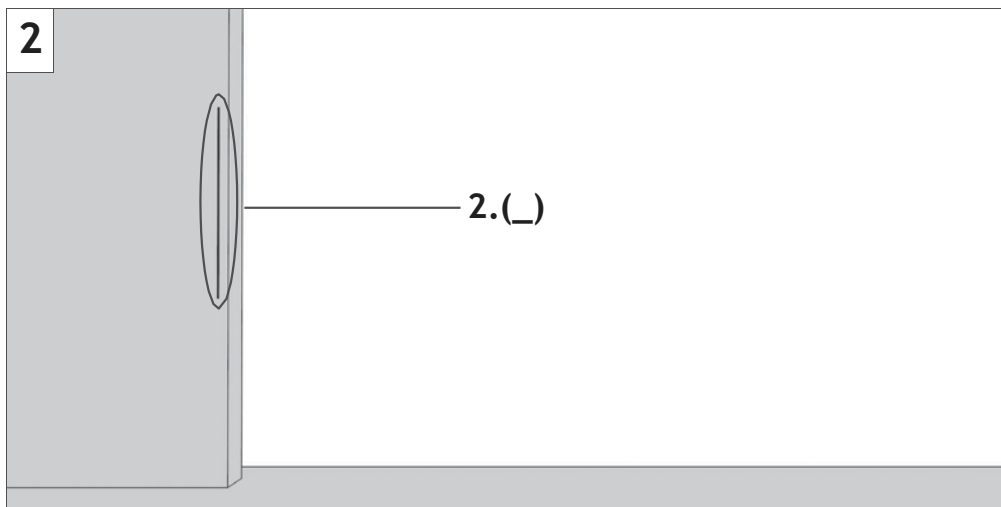

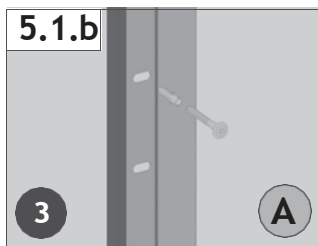
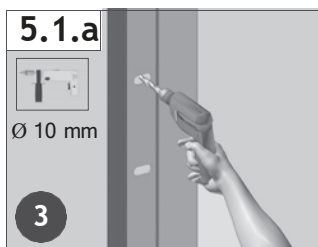
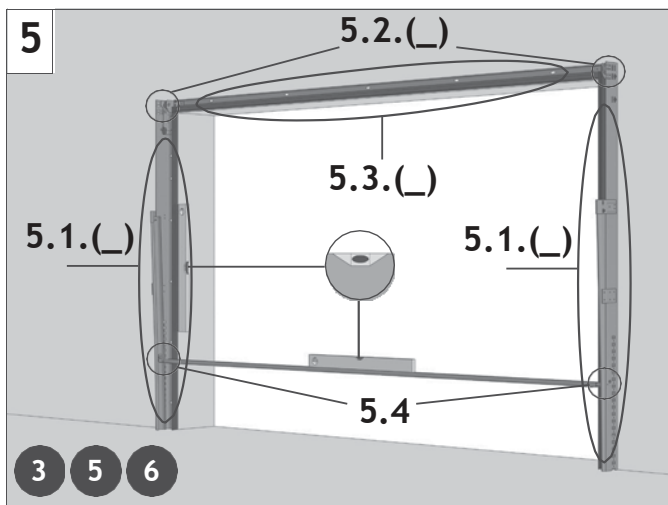
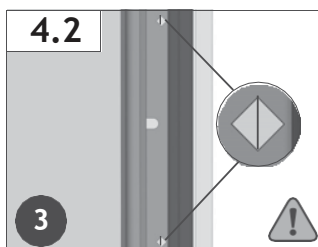
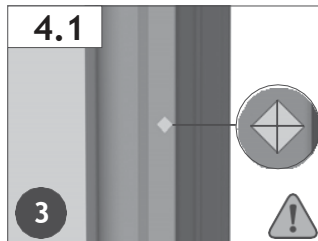
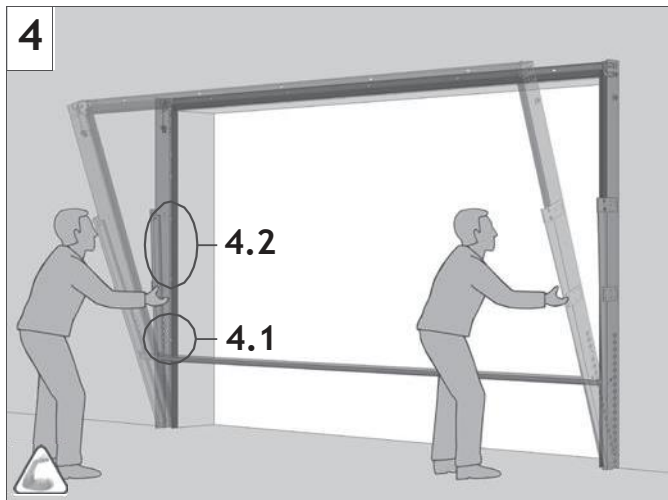
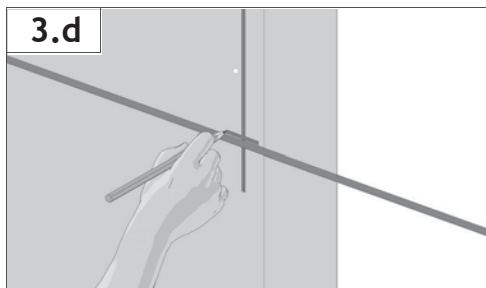
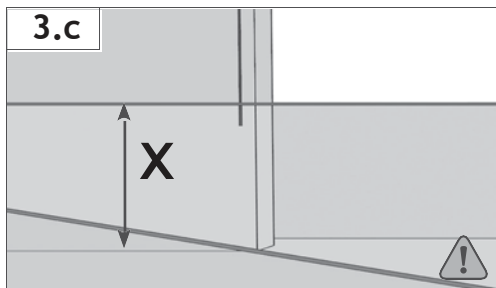

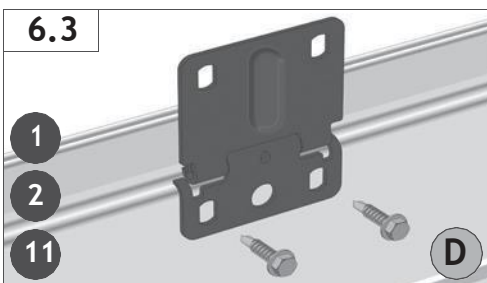
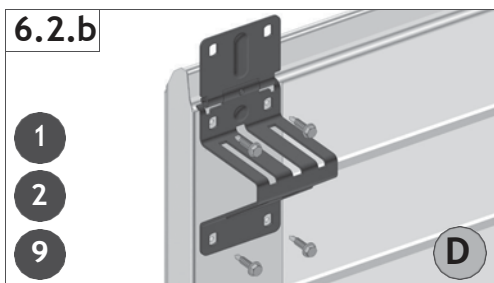
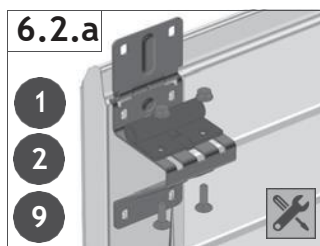
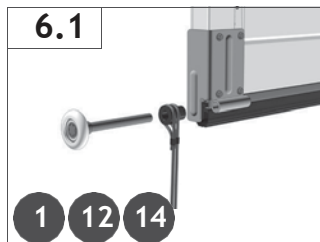
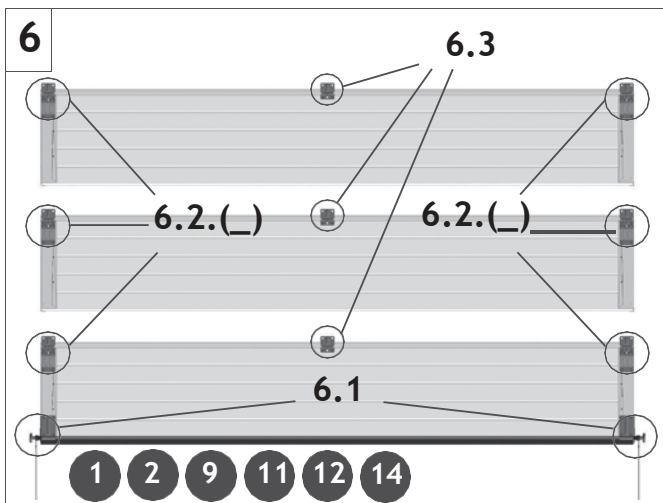
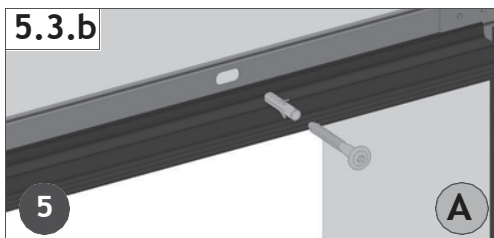
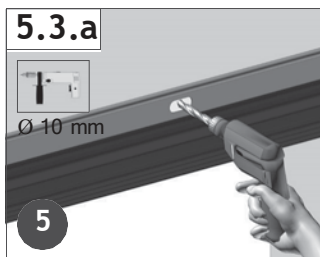
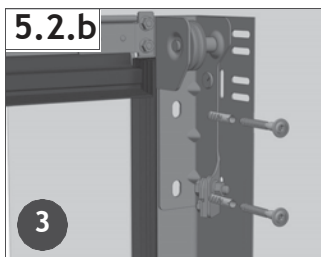
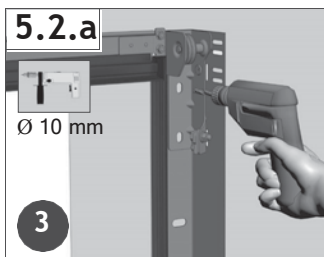

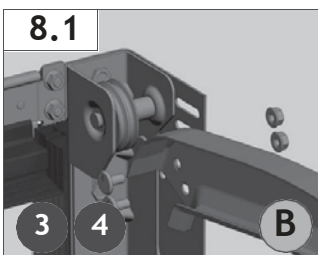
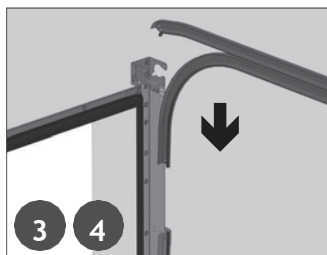
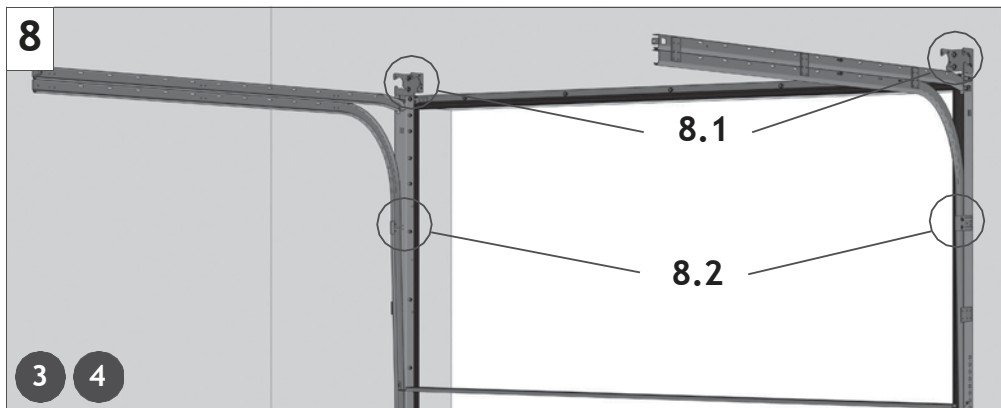
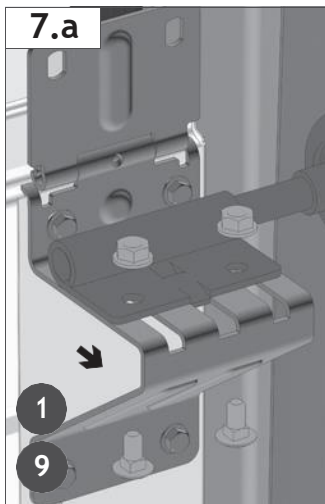
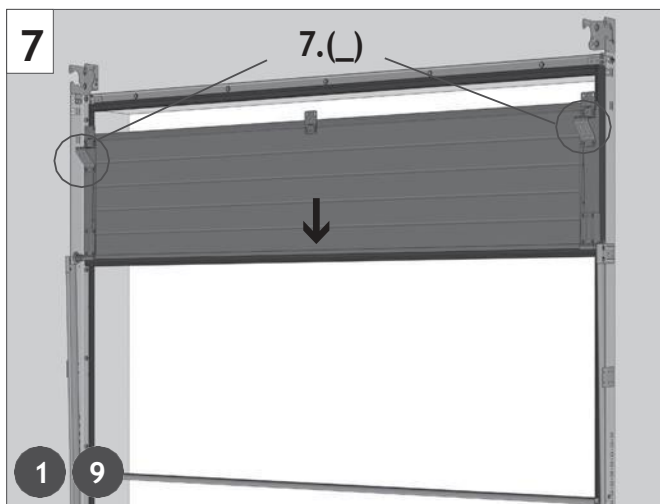

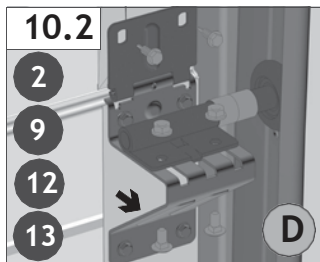
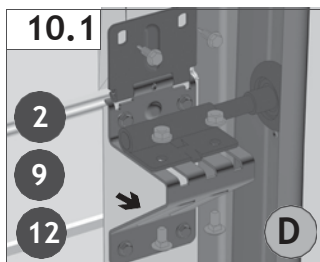
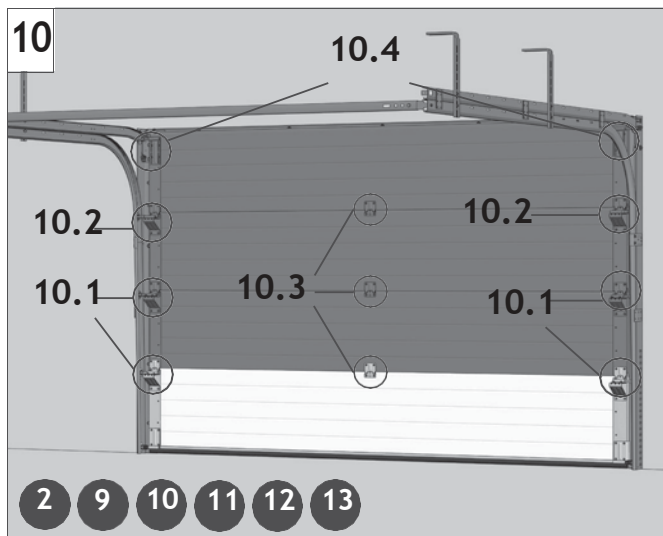
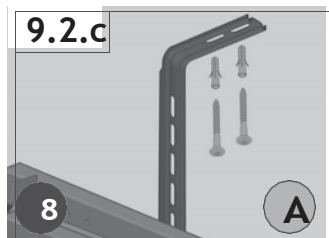
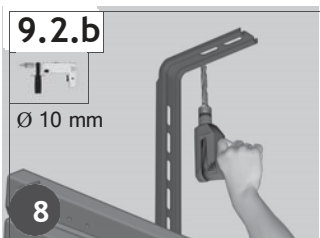
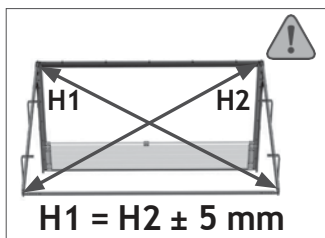
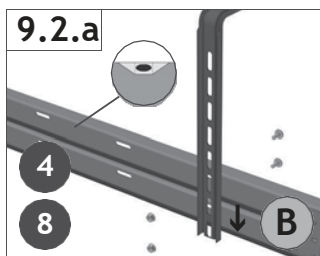
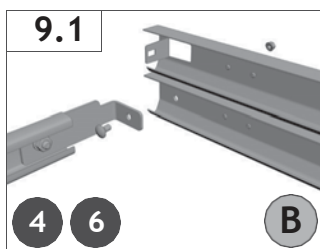
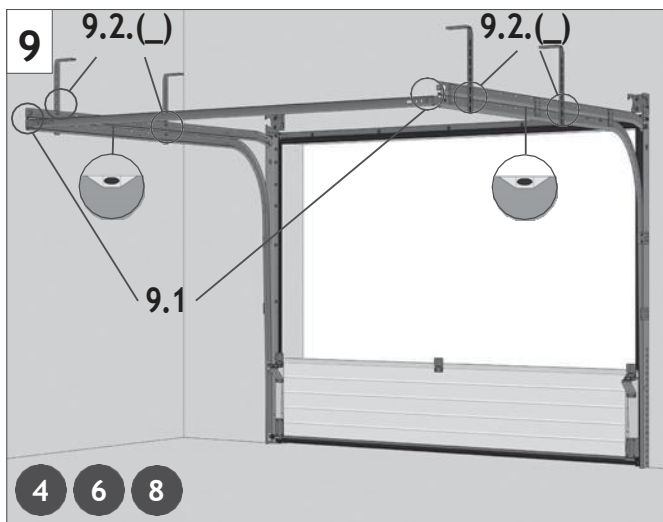

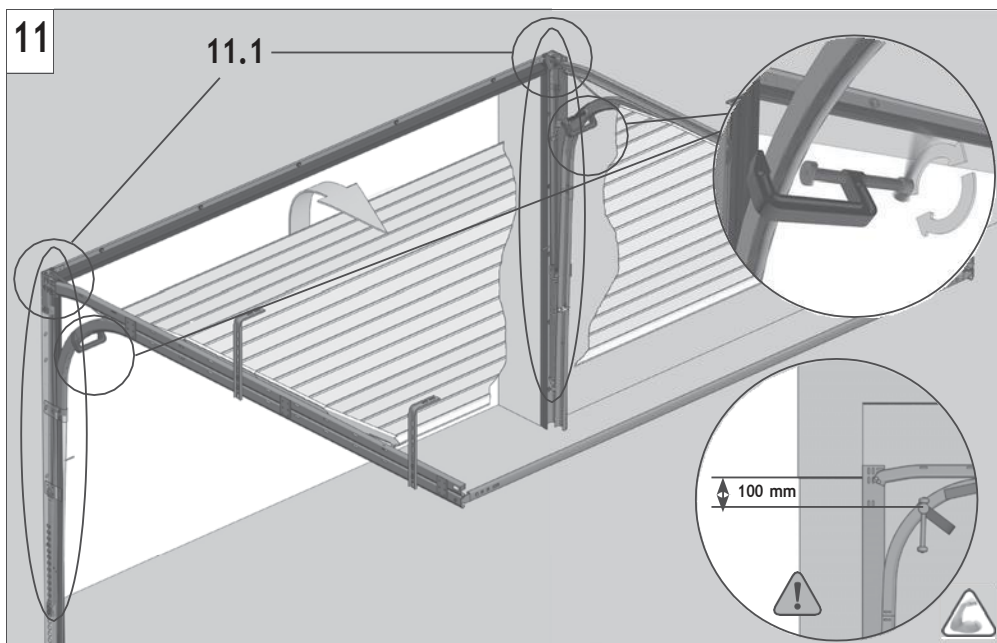
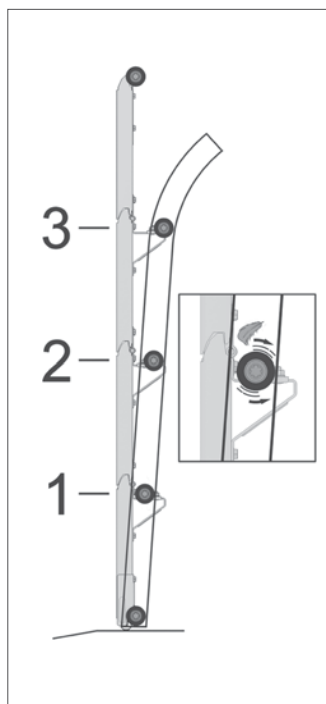
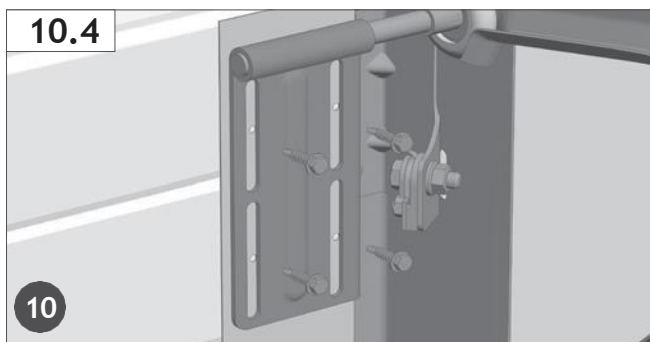
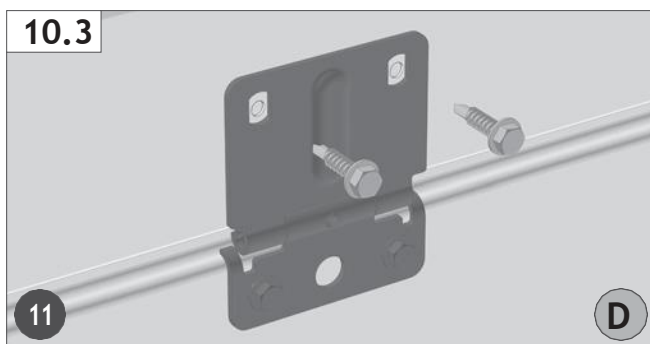

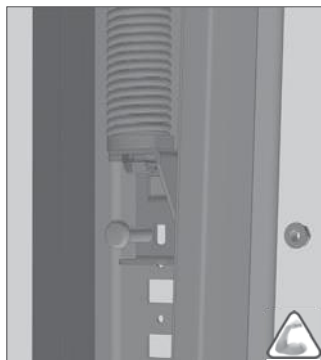
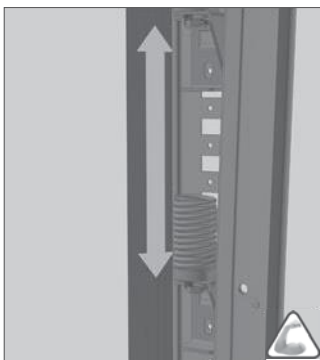
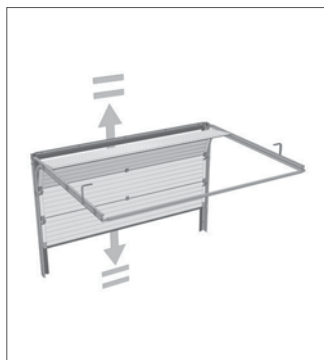
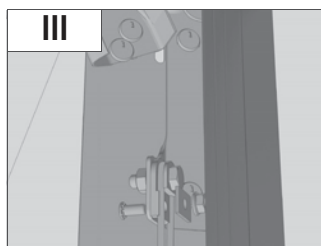
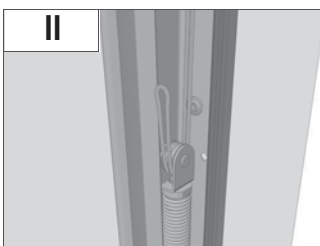
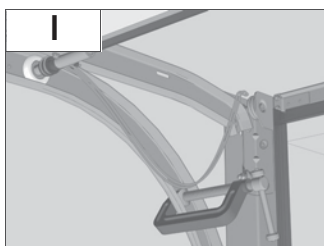
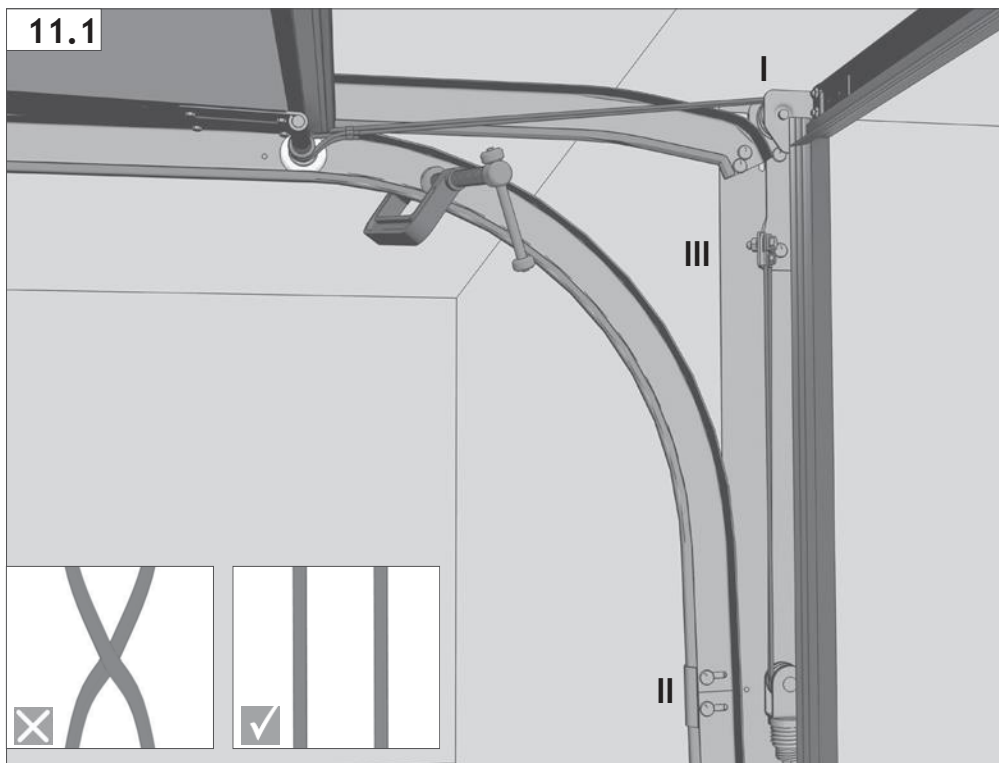

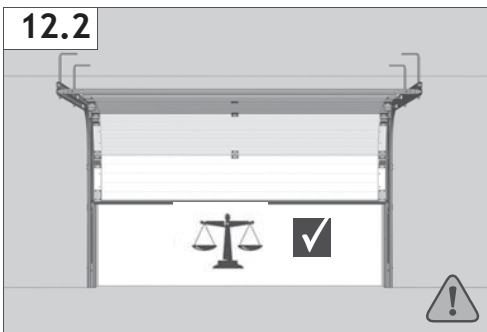
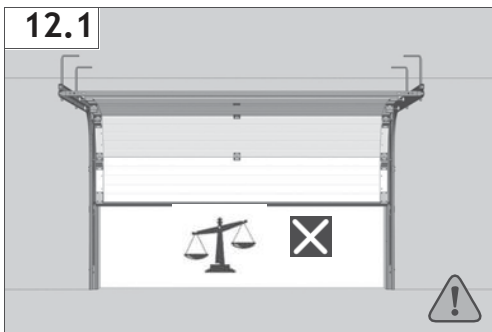
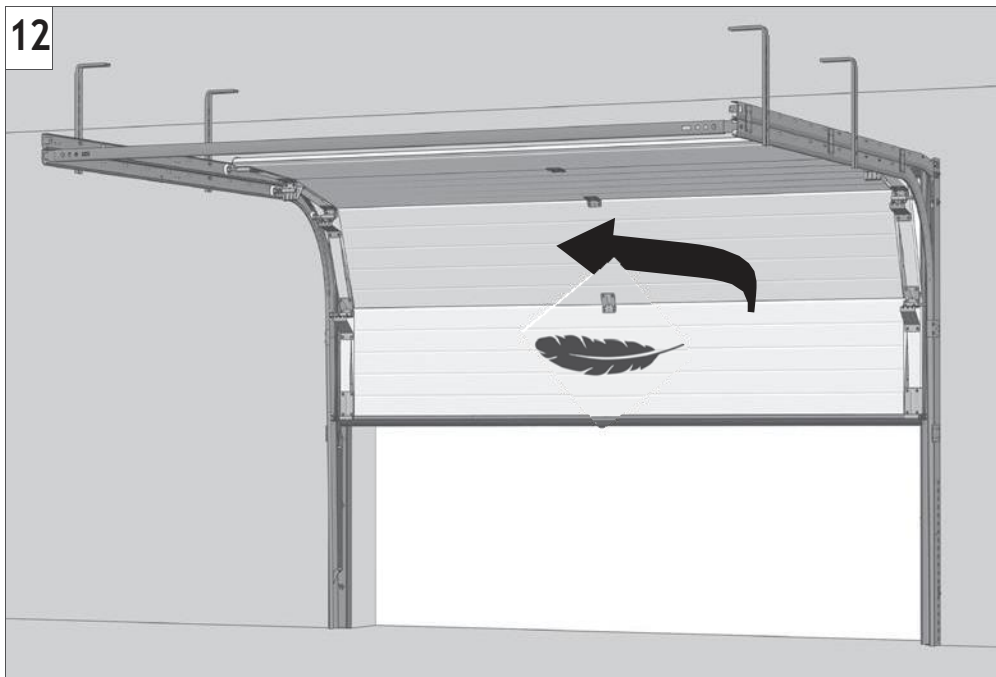
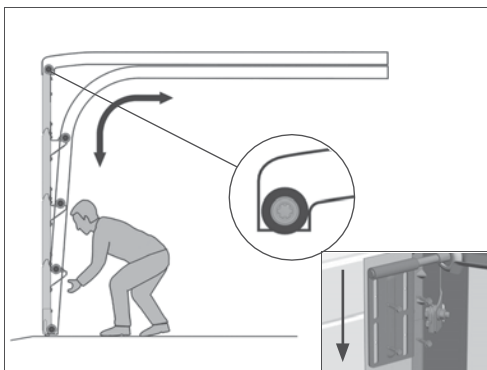
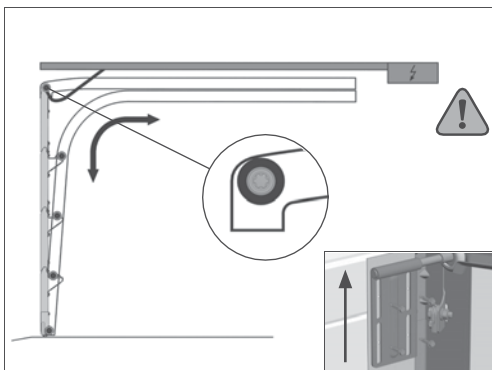

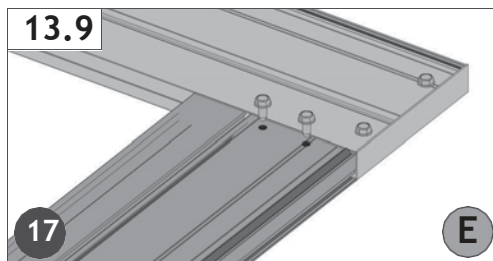
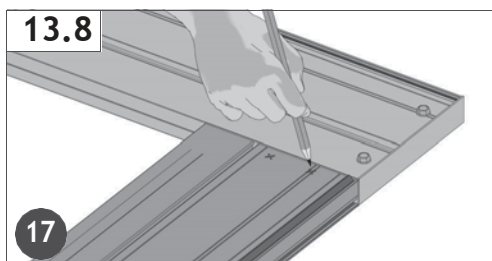
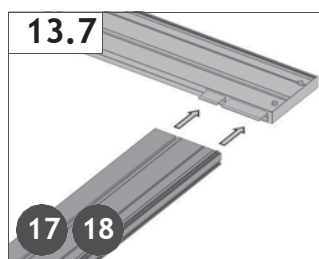
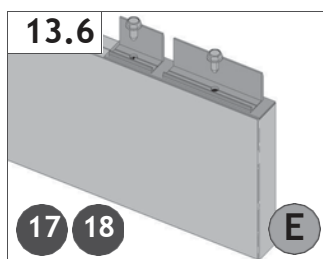
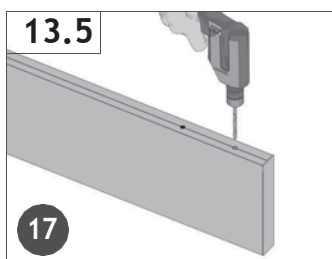
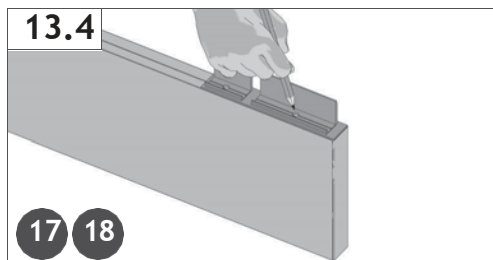
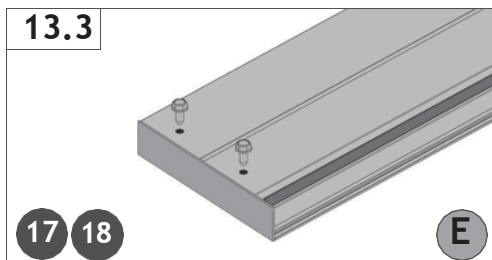
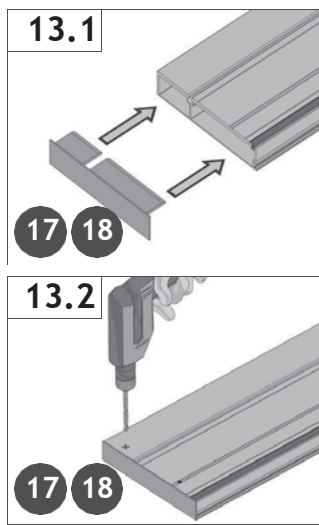
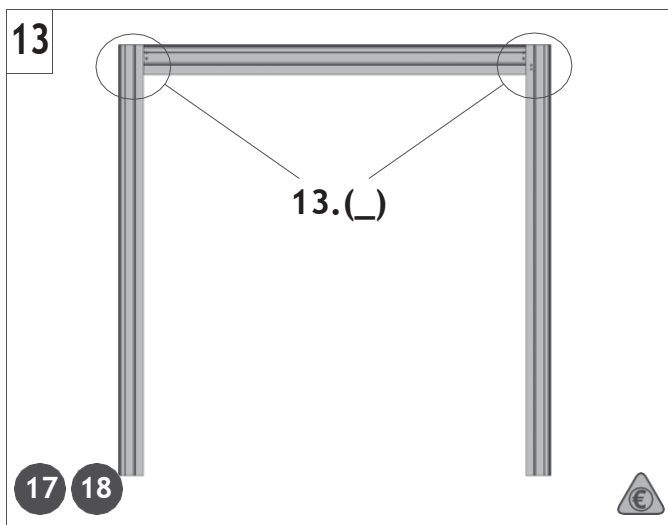

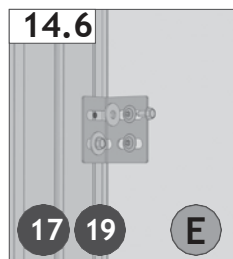
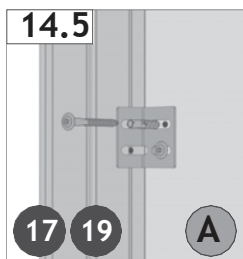
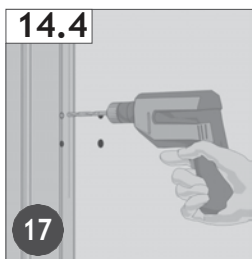
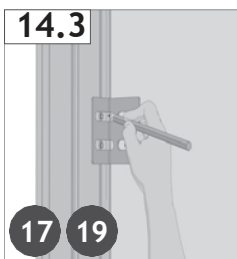
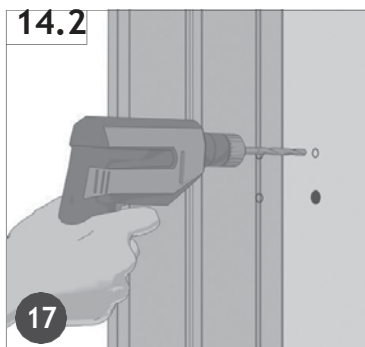
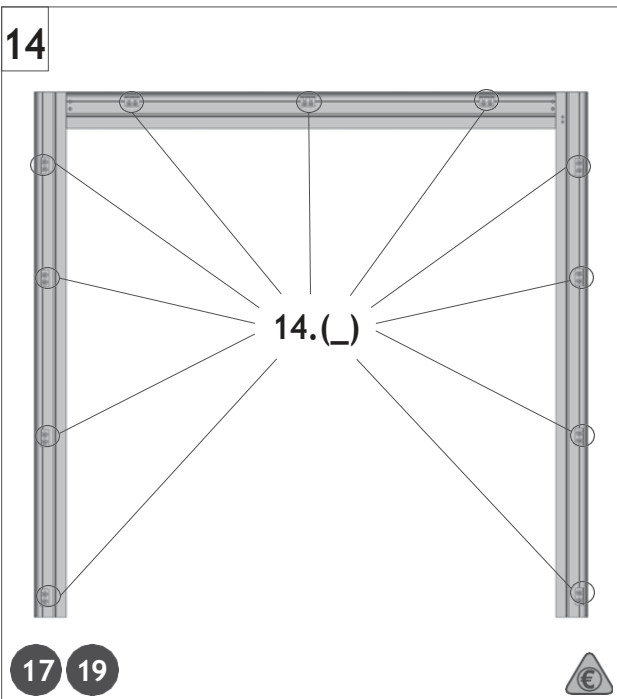
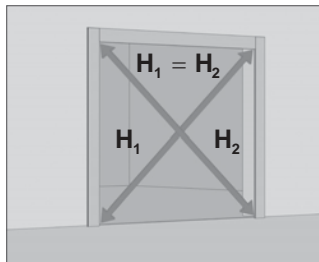
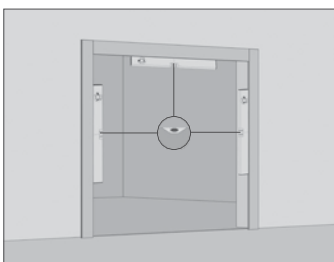
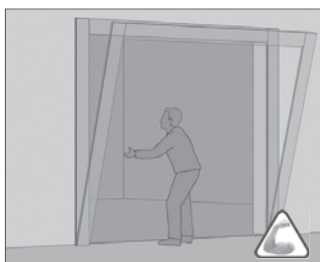

# СЕКЦІЙНІ ВОРОТА FUA02 НИЗЬКИЙ ПІДЙОМ

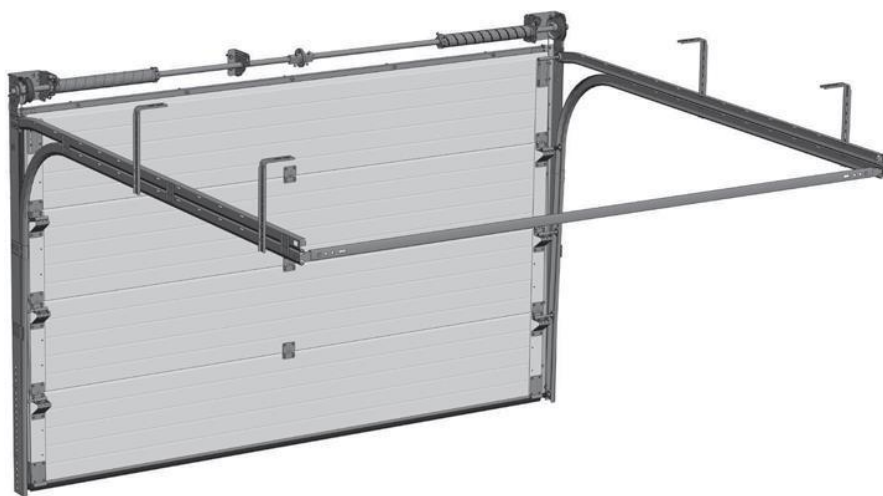

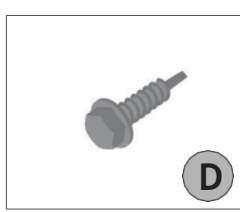
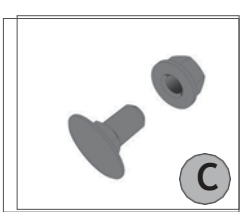
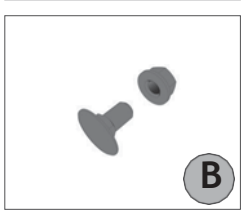
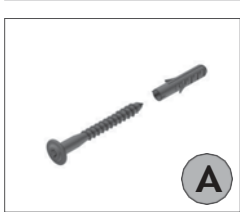
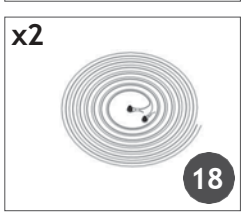
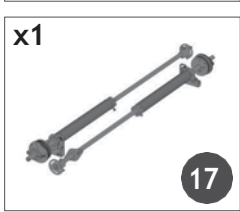
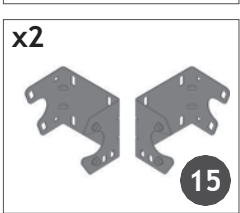
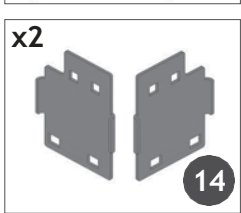
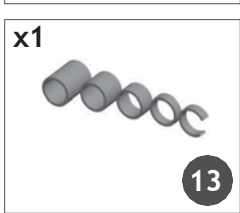
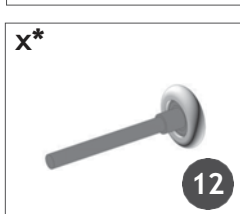
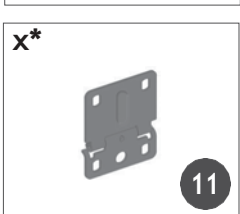
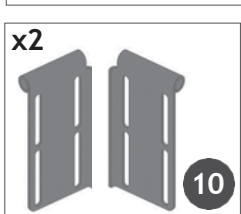
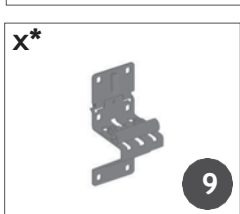
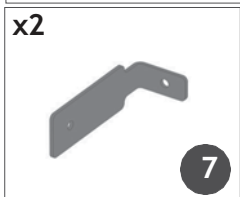
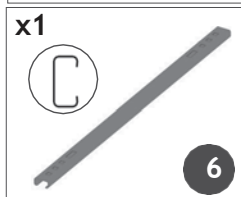
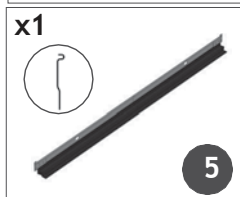
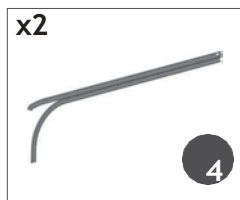
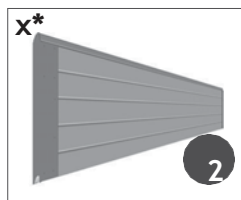
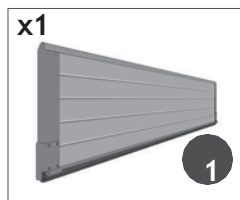

8 × 70 mm

M 6 × 16 mm

M 6 × 16 mm

6,3 × 32 mm

x\* – calculated individually

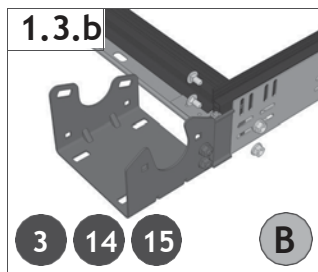
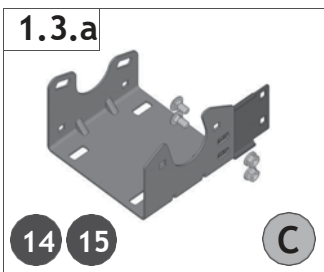
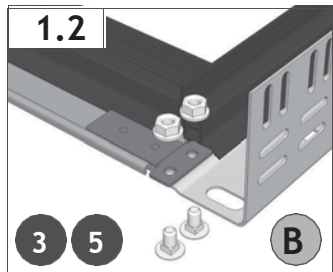
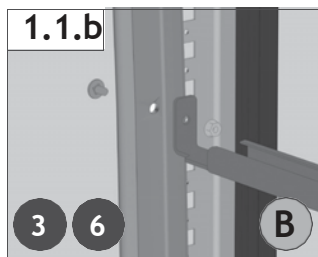
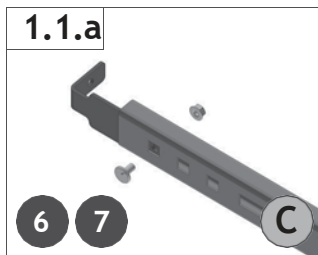
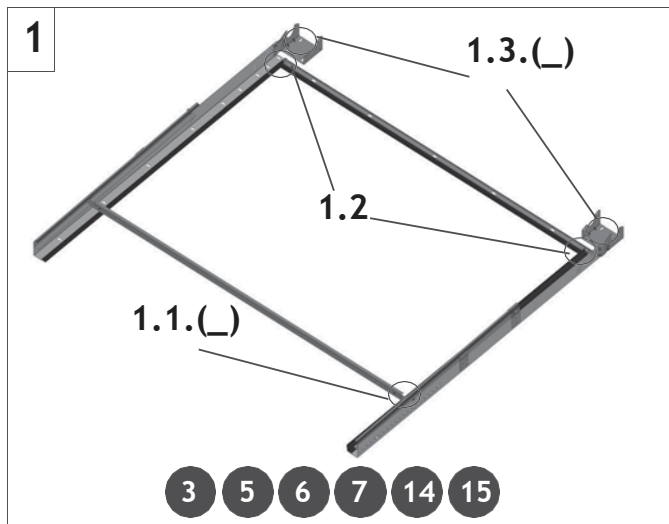
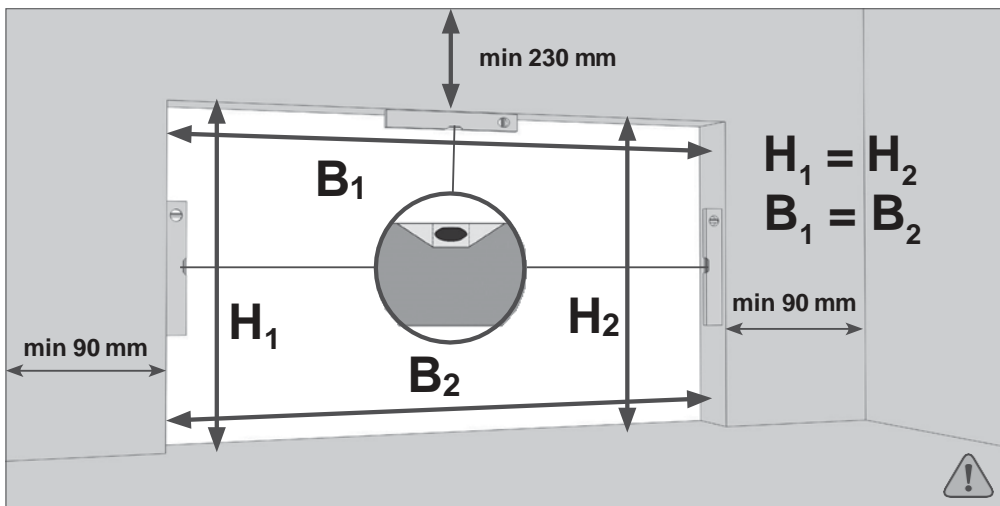

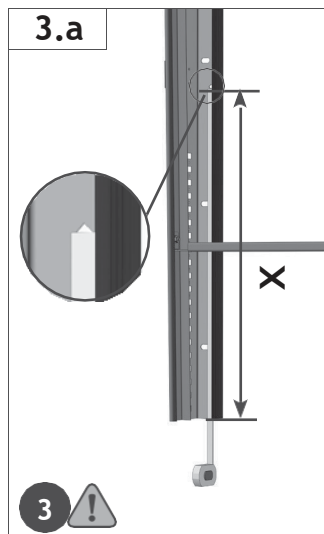
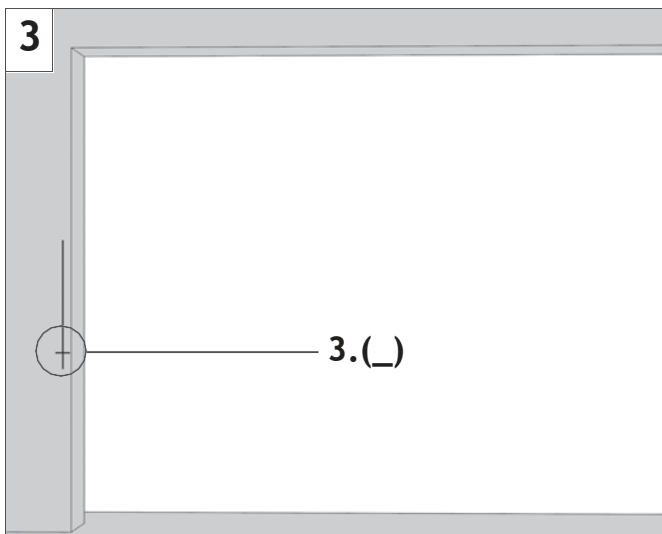
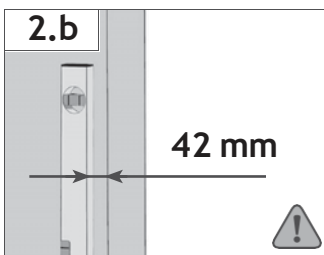
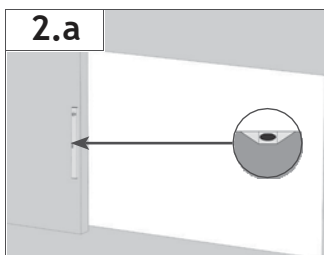
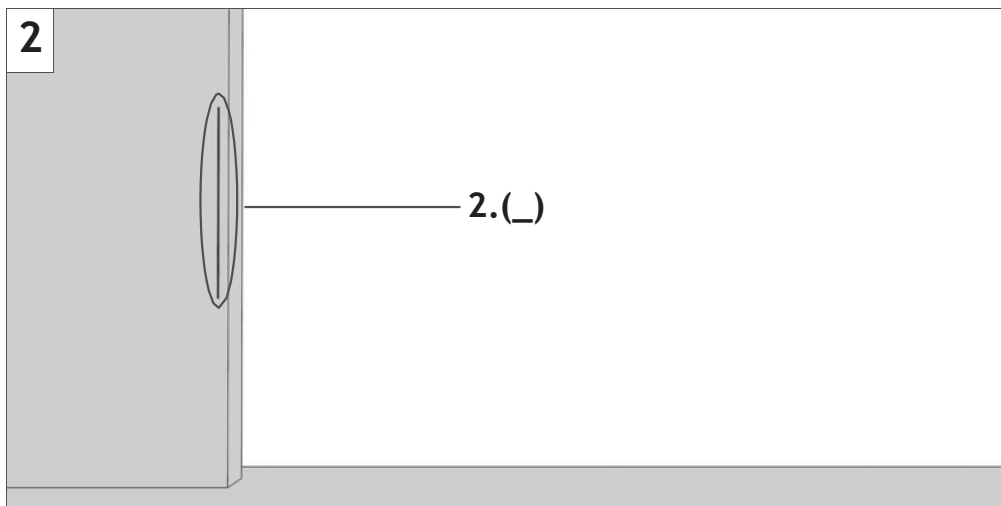

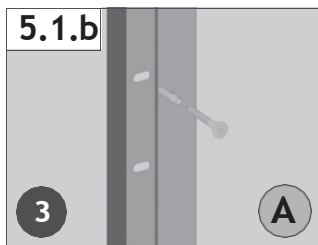
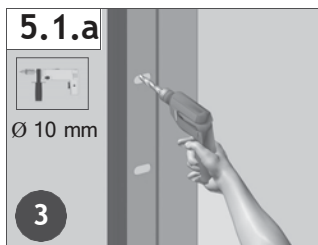
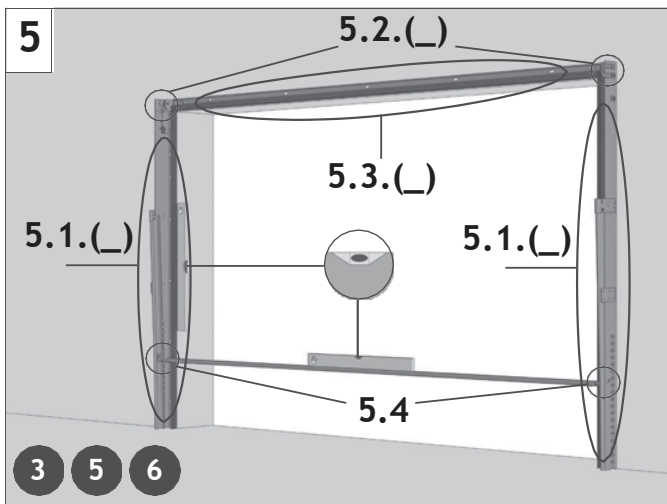
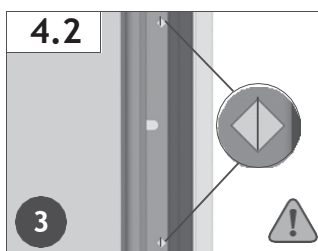
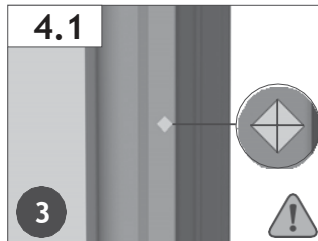
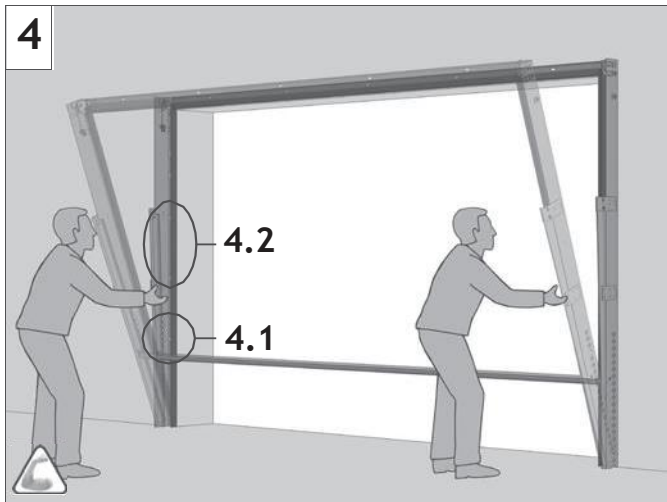
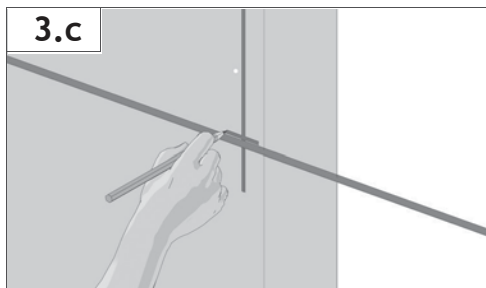
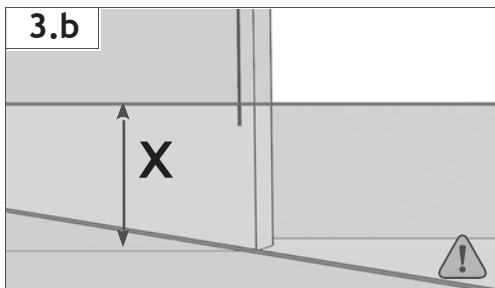

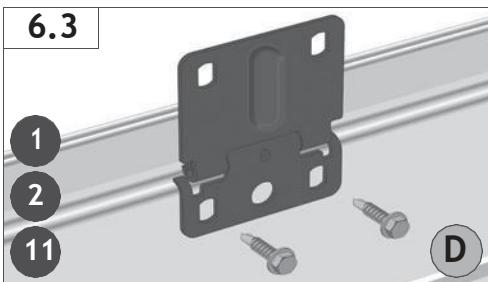
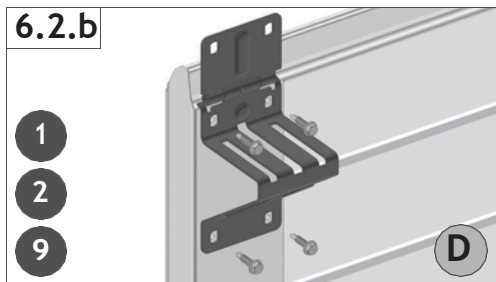
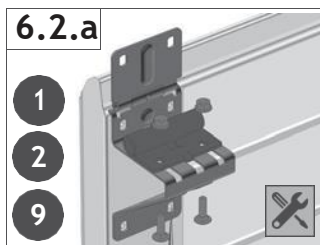
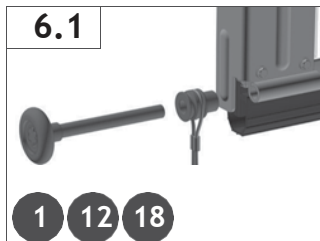
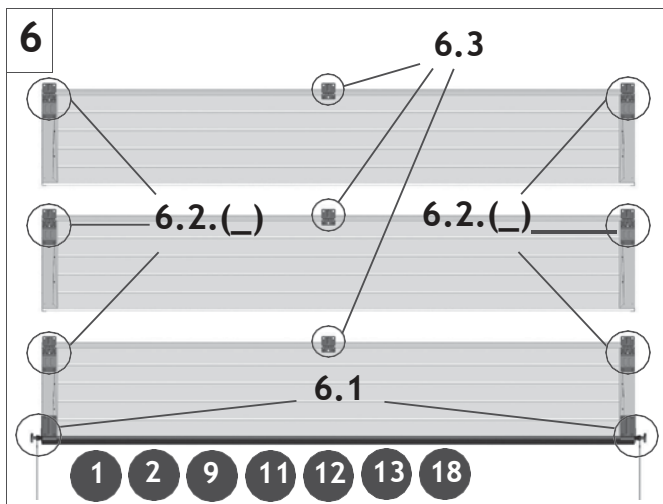
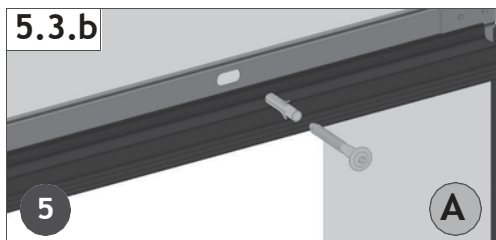
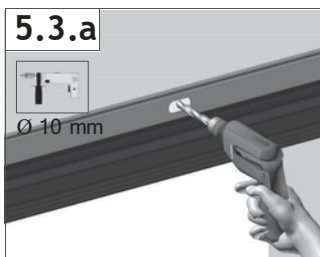
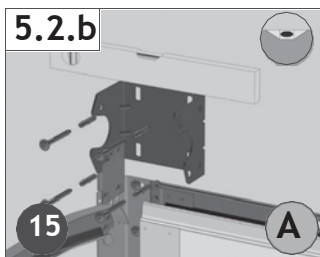
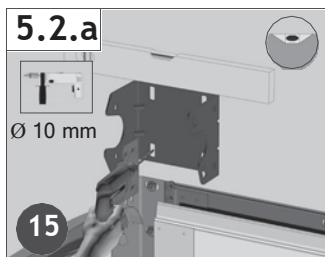

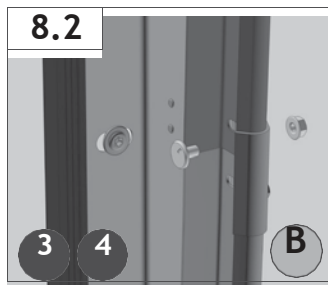
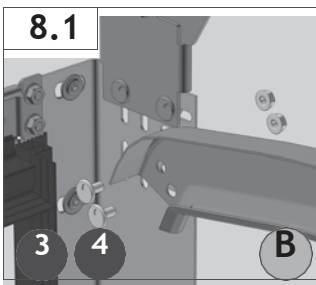
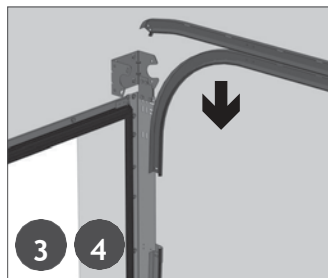
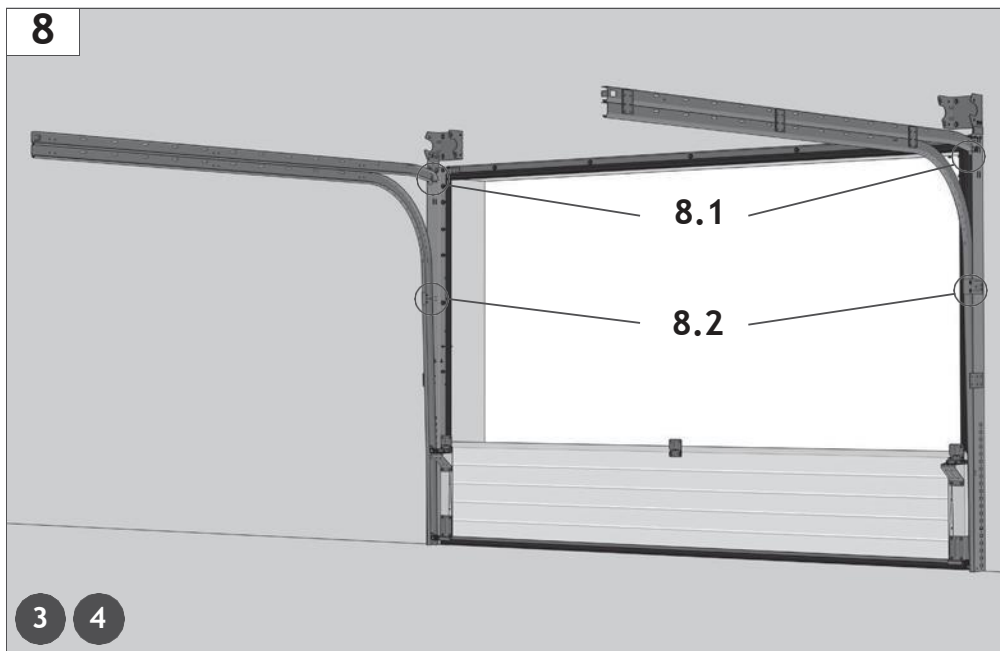
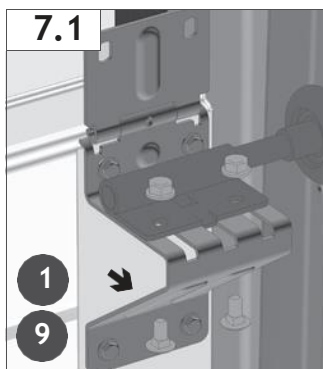
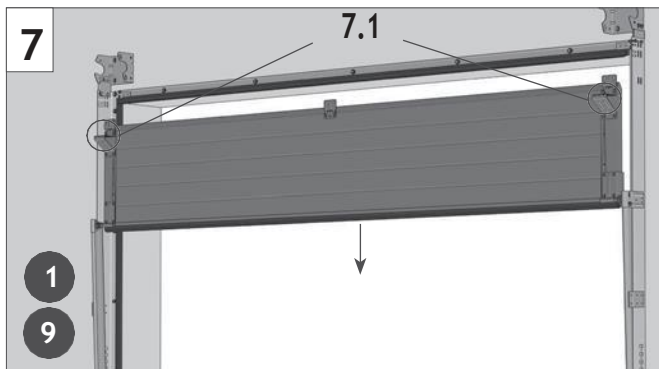

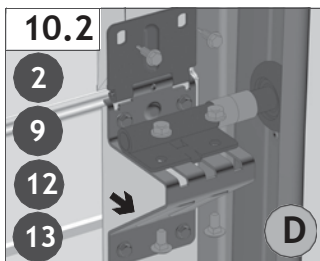
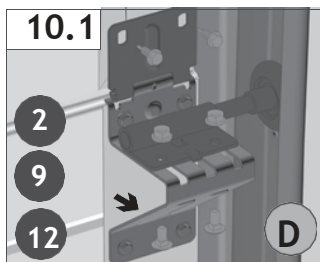
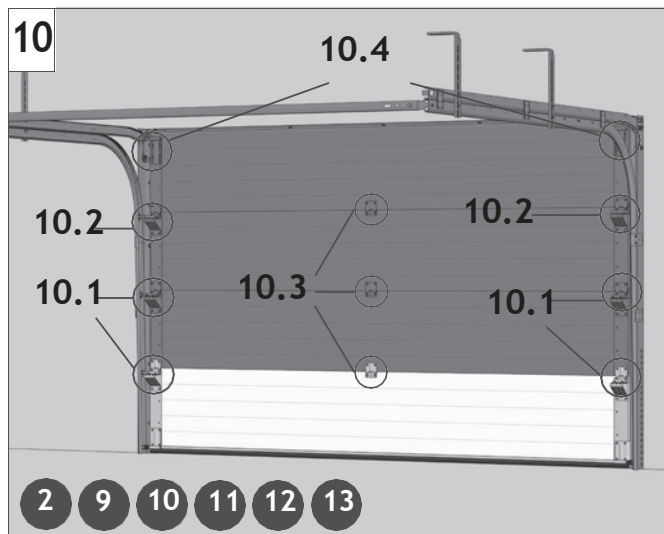
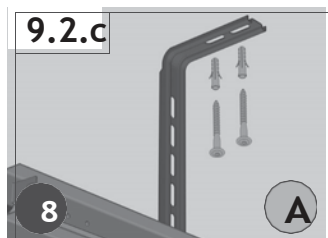
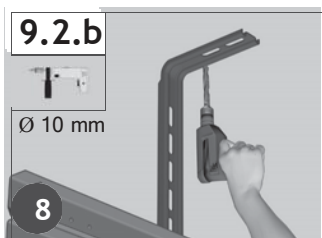
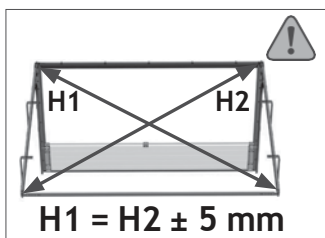
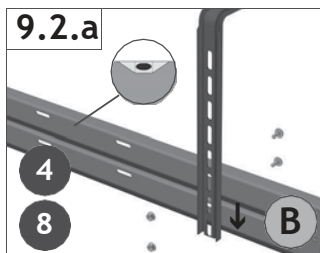
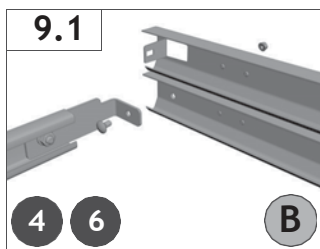
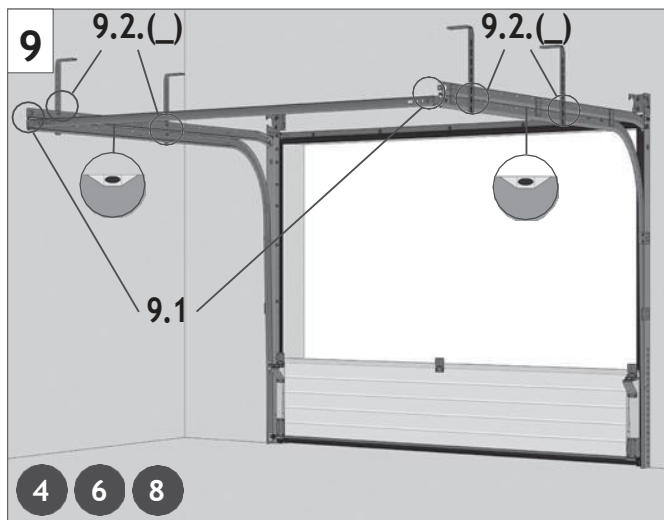

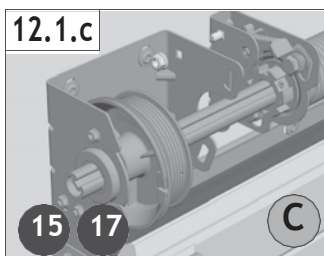
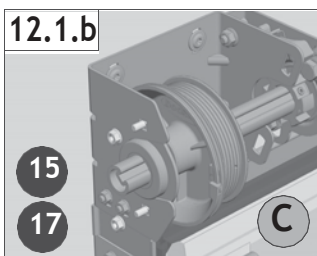
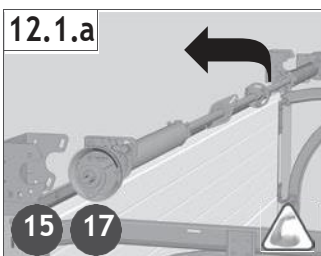
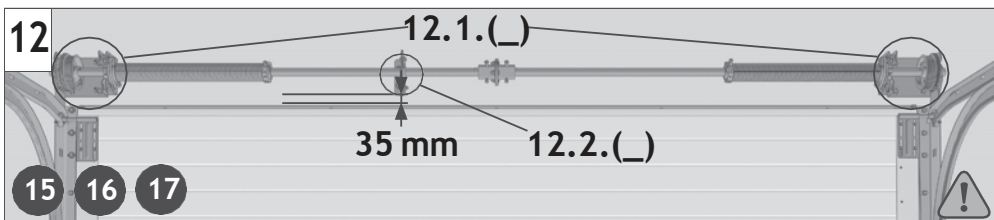
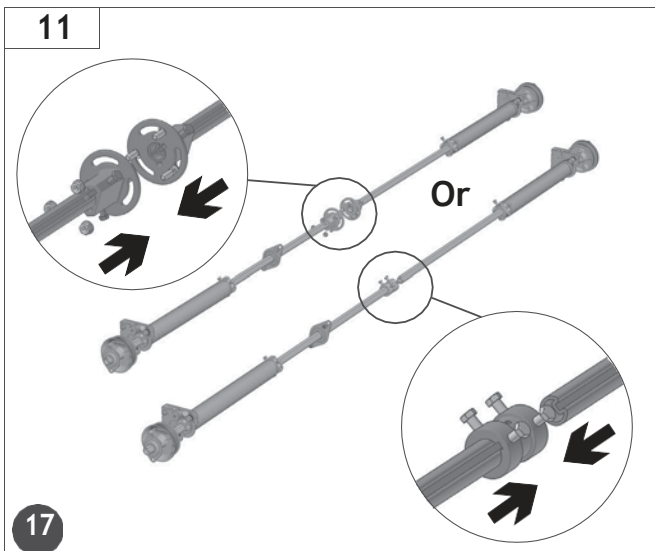
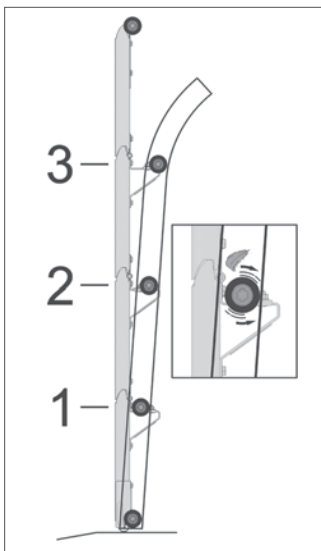
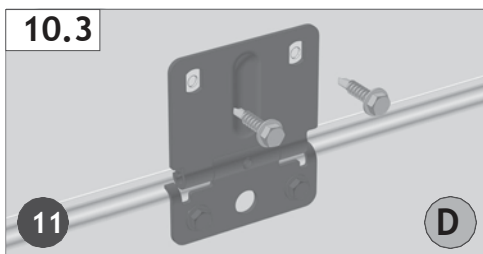

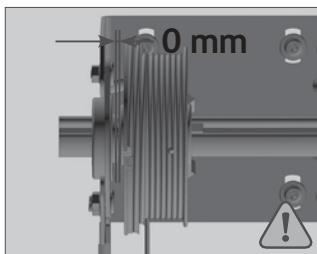
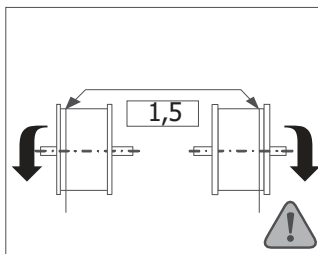
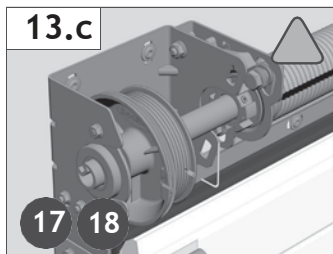
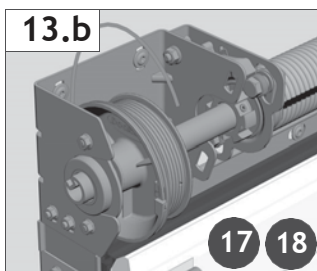
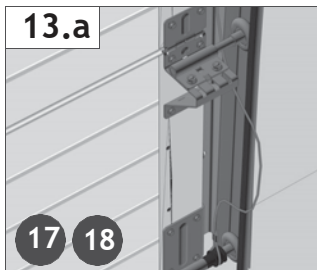
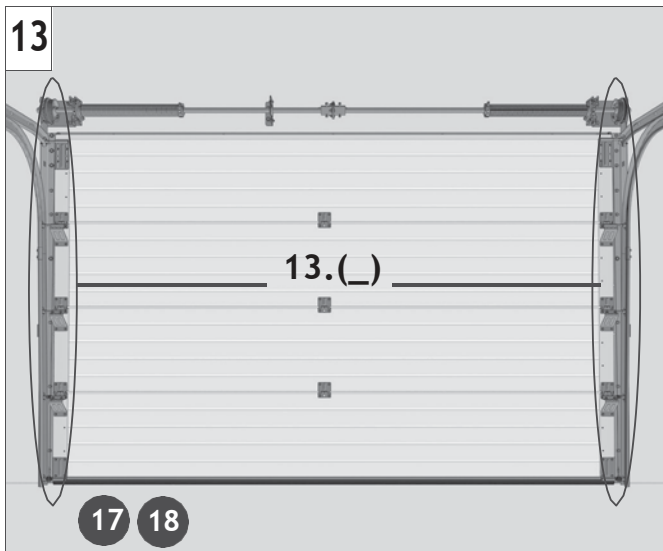
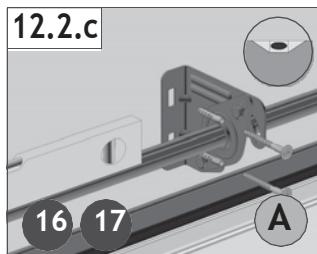
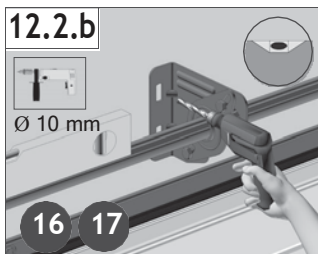
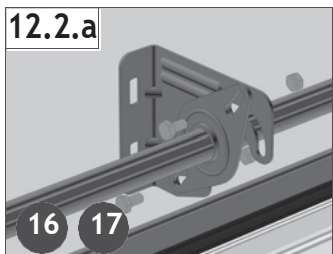

<b>FuturaGate</b>	
Serial number:	<input type="text"/>
Order number:	<input type="text"/>
Type:	Lift: <input type="checkbox"/> SL <input type="checkbox"/>
Springs:	N <input type="checkbox"/> L <input type="checkbox"/> D <input type="checkbox"/> d <input type="checkbox"/> n <input checked="" type="checkbox"/> z
Weight of door:	<input type="text"/>
Year of production:	<input type="text"/>
Heat conductivity factor:	<input type="text"/>

!

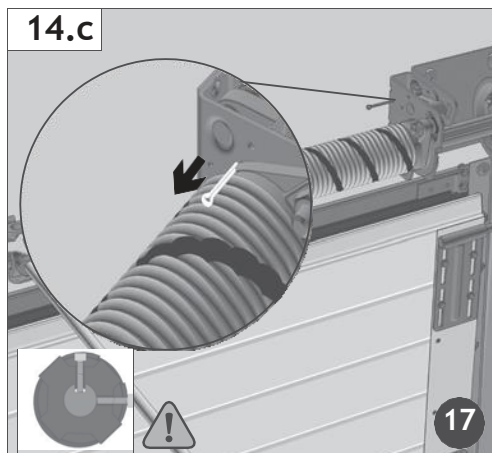
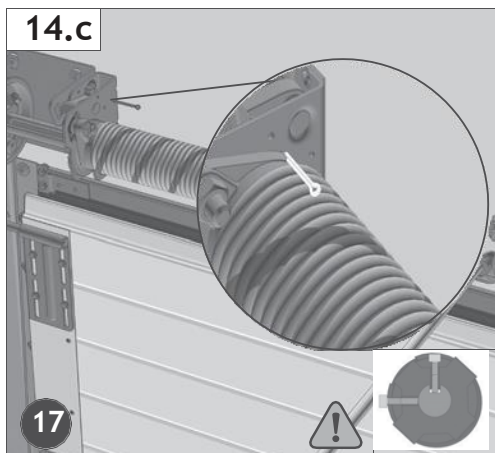
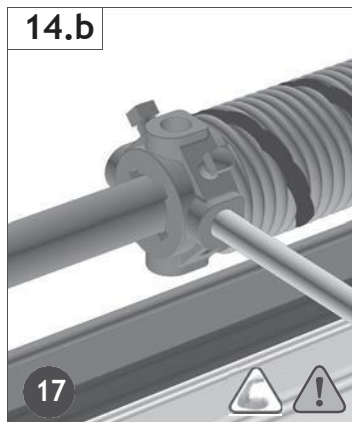
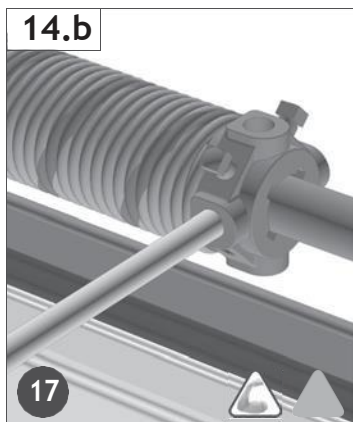
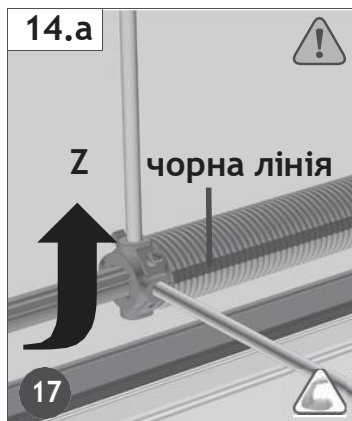
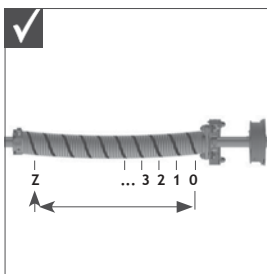
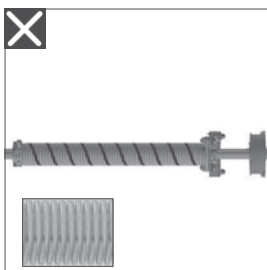

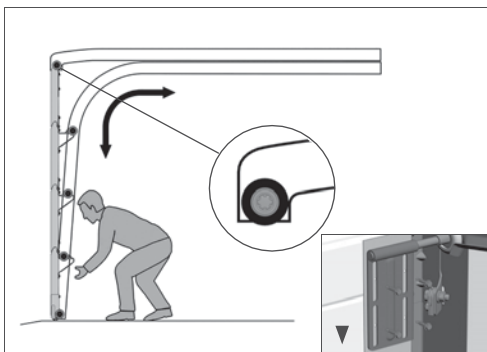
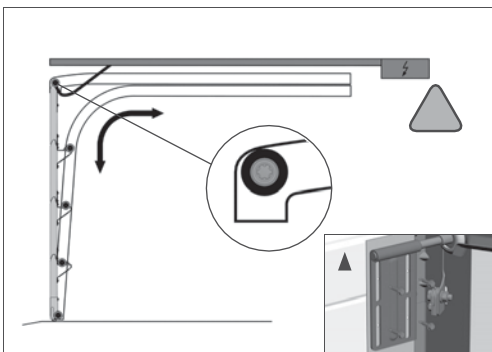
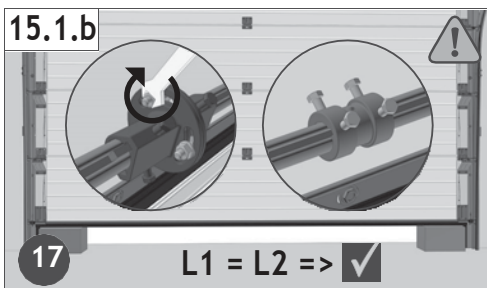
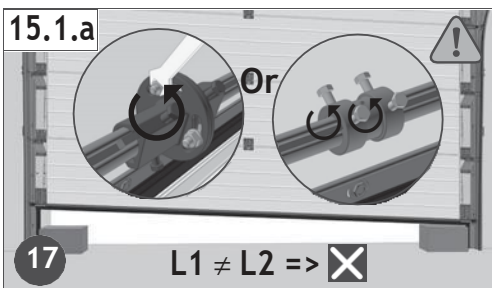
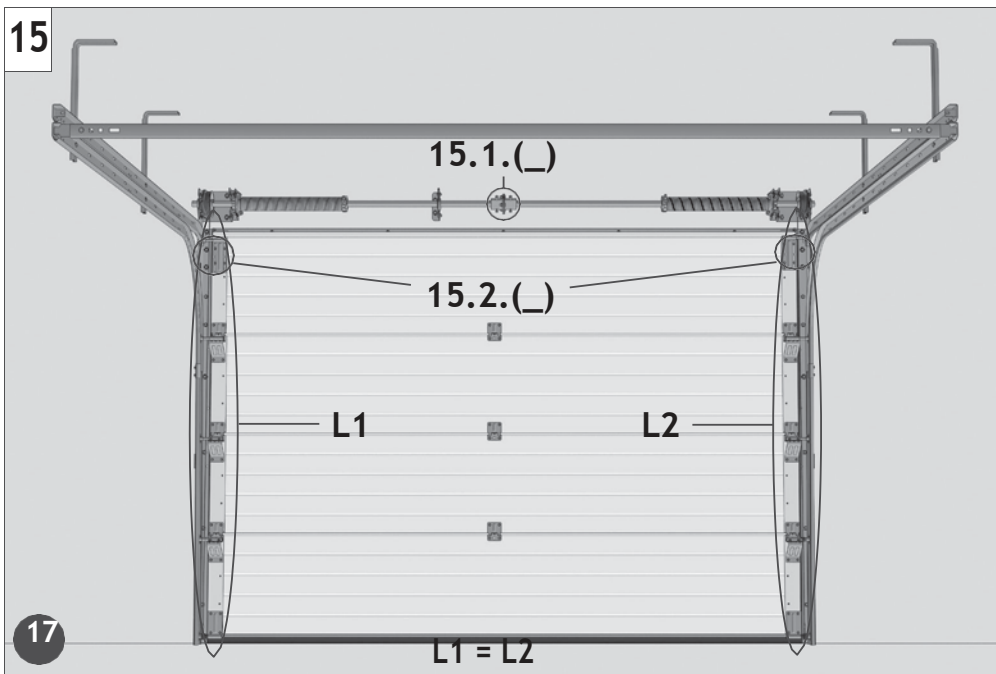

16

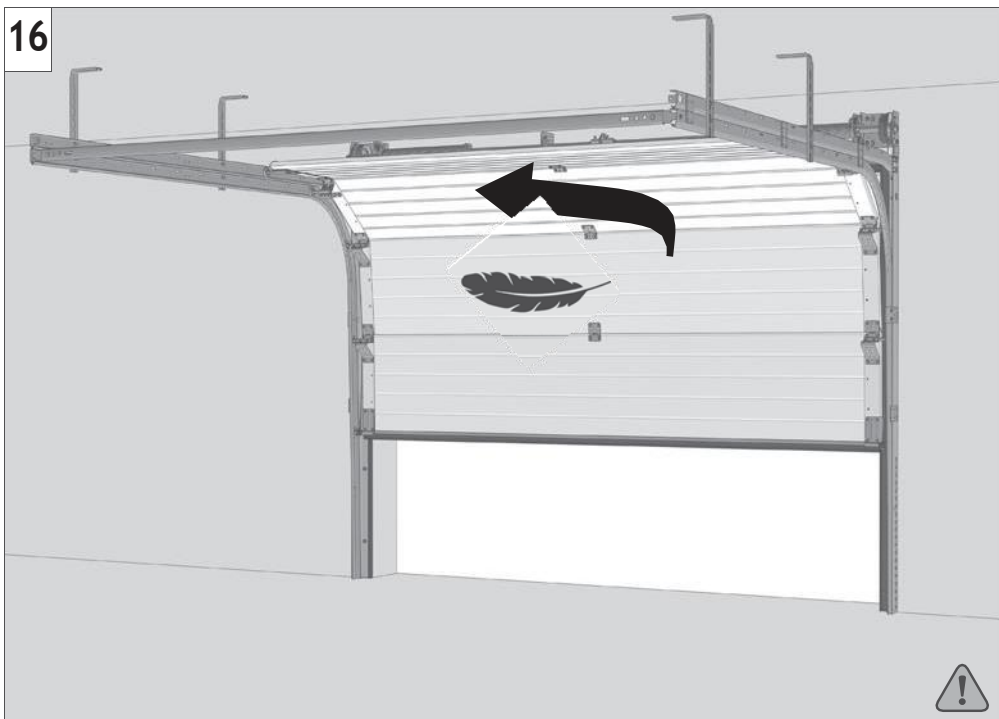

16.1

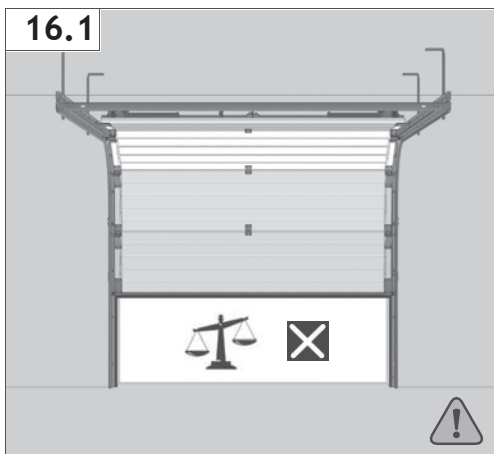

16.2

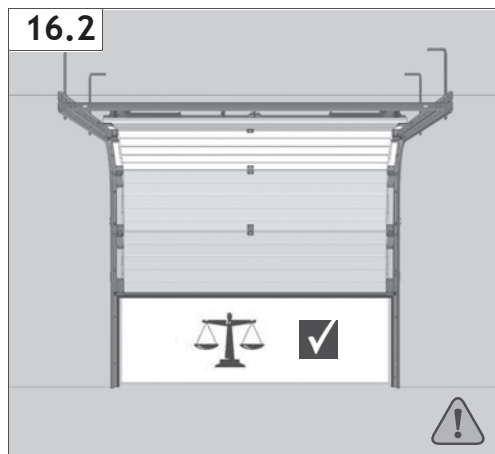

# Секційні ворота FUA02 з притолкою від 150мм до 220мм

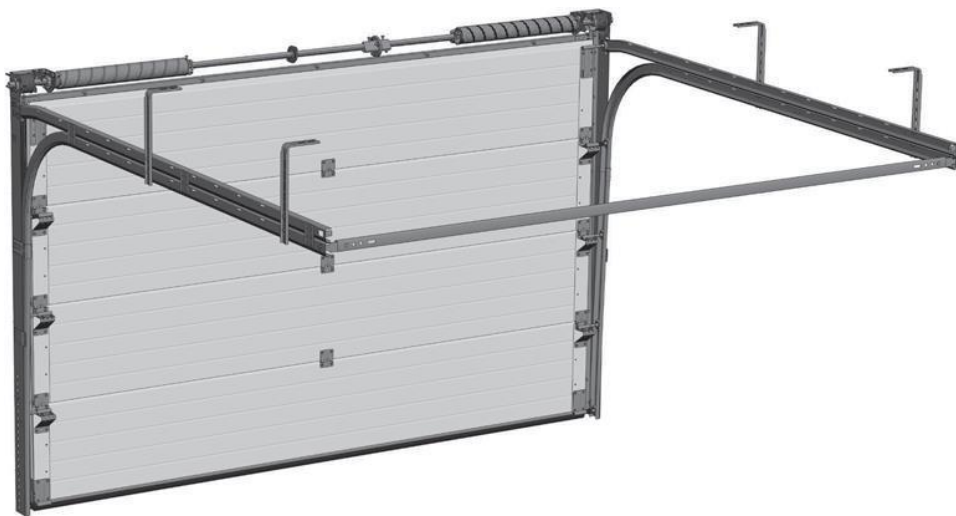

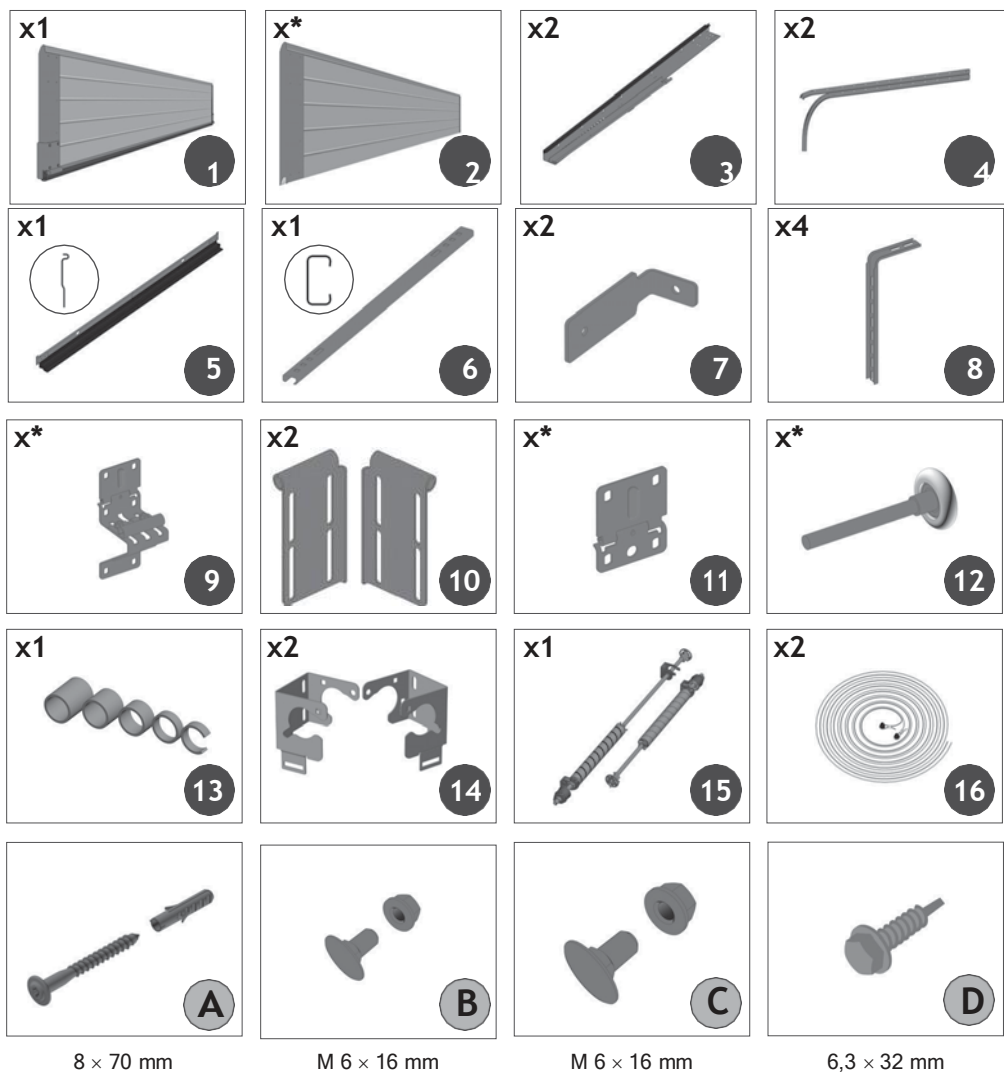

x\* – індивідуальний розрахунок

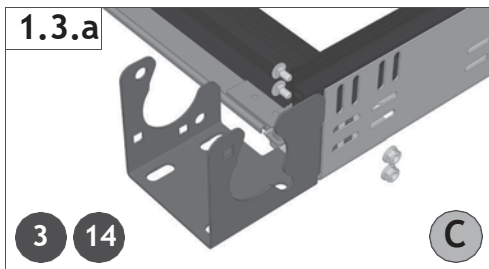
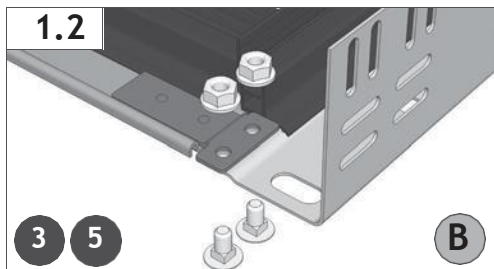
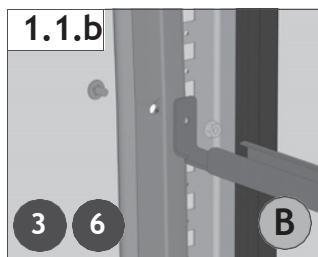
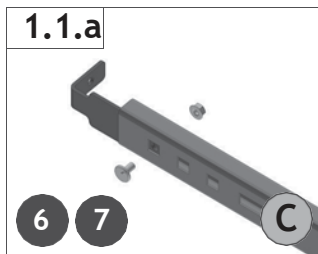
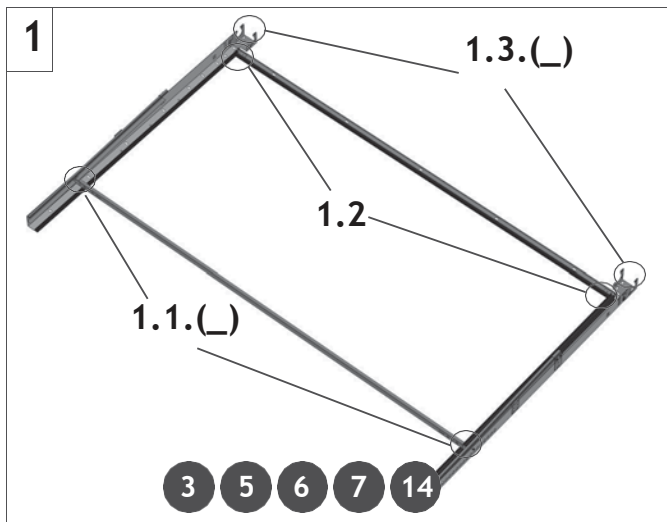
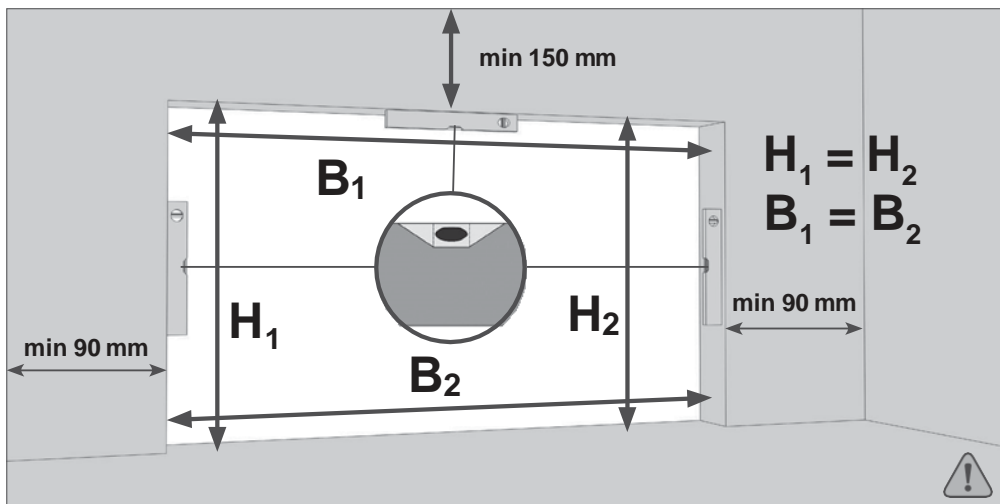

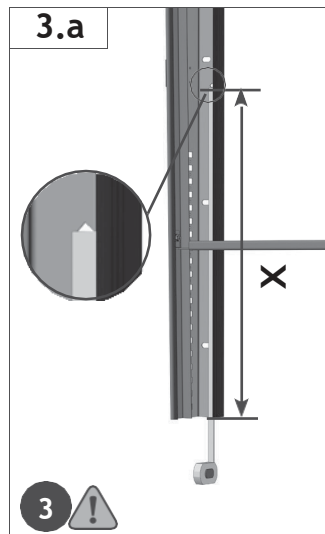
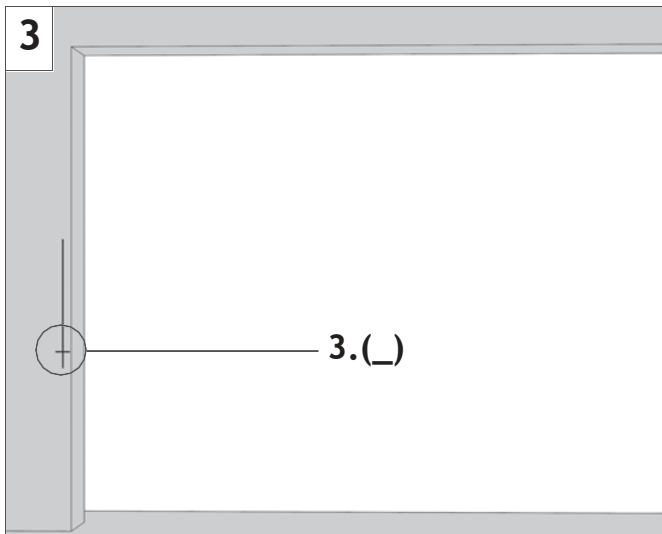
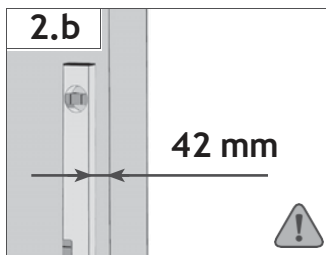
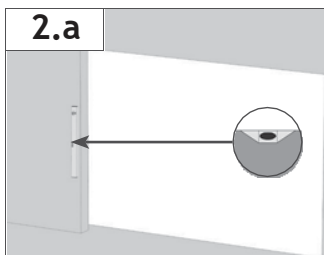
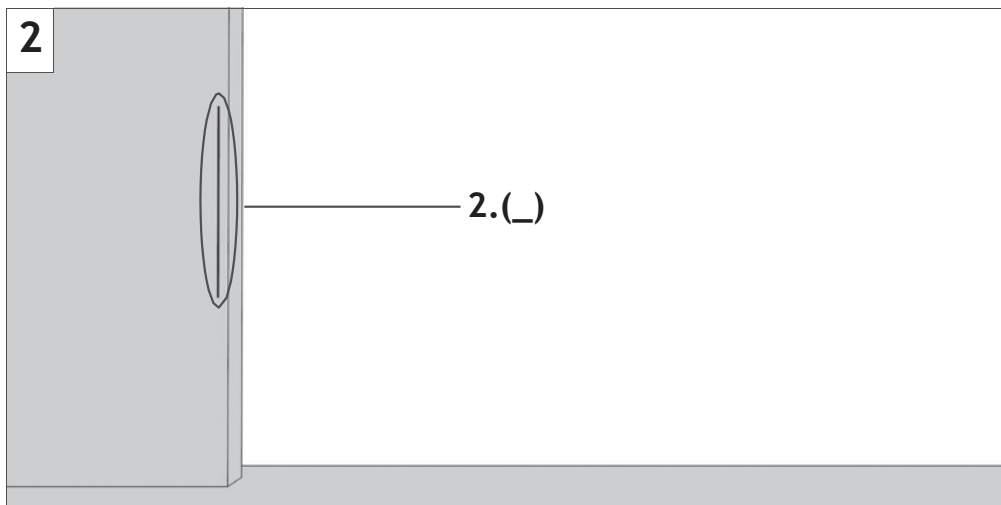

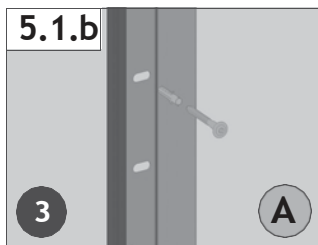
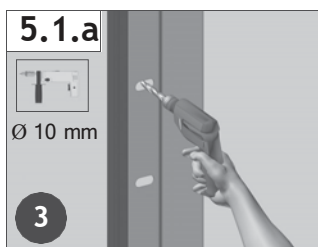
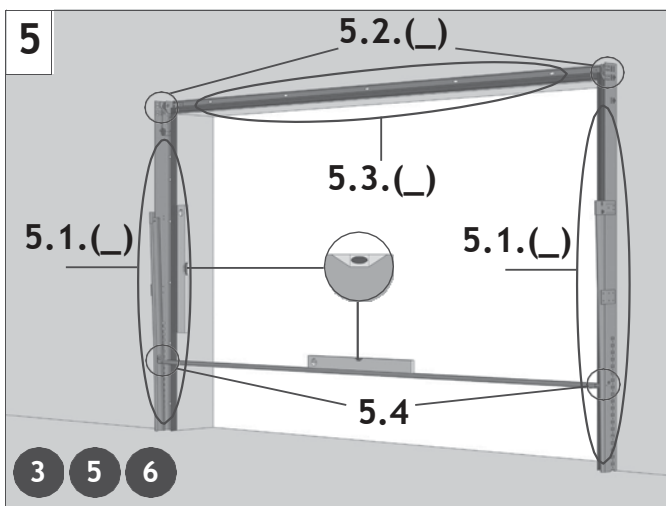
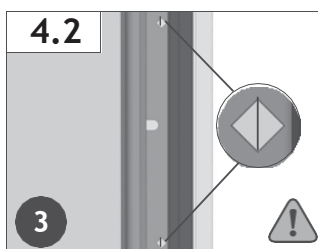
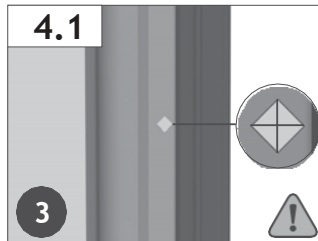
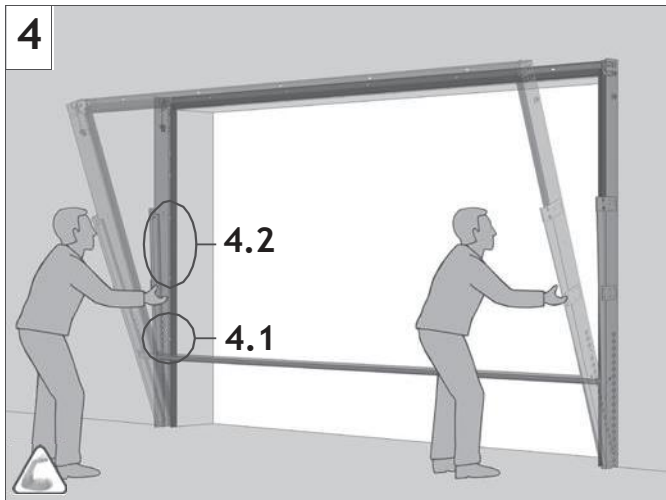
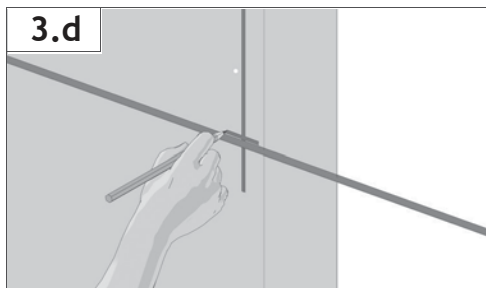
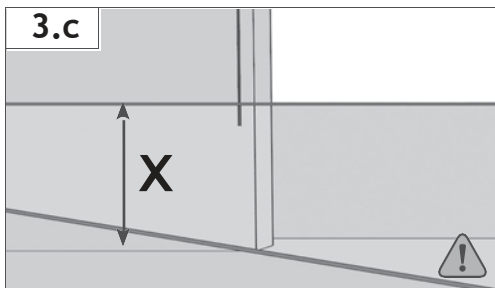

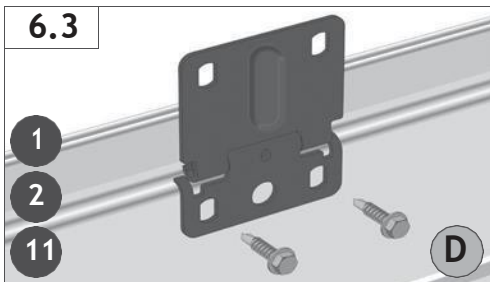
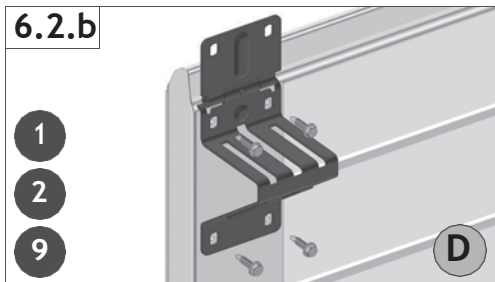
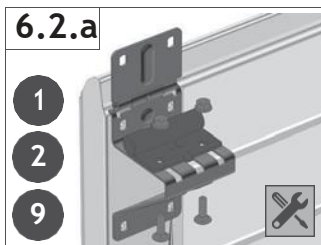
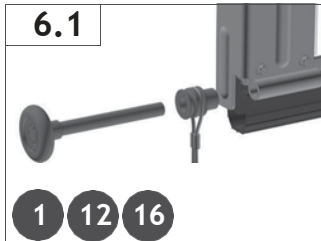
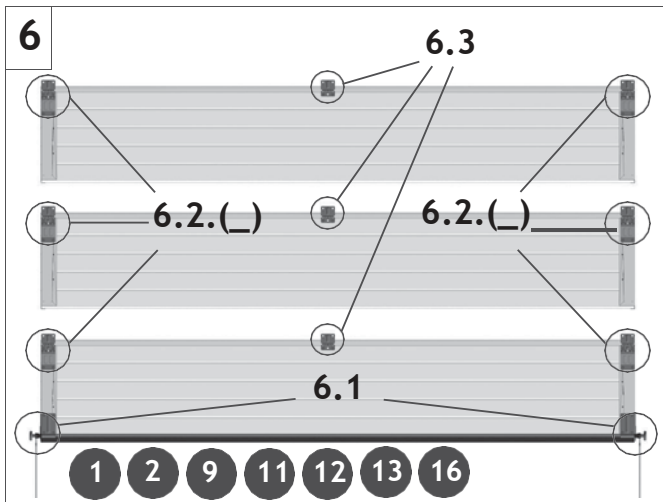
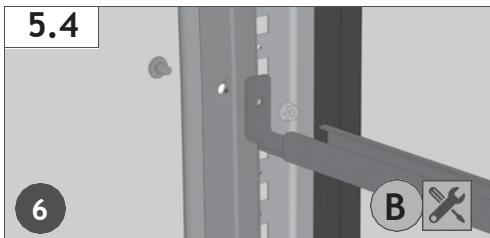
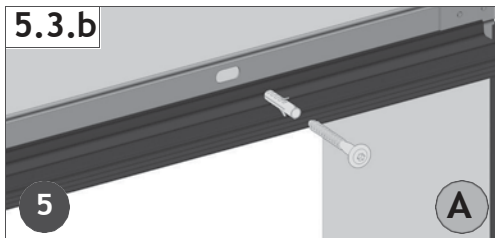
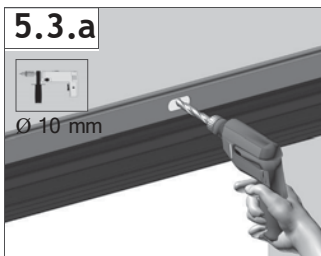
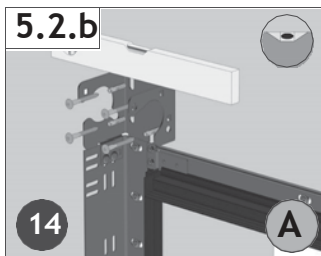
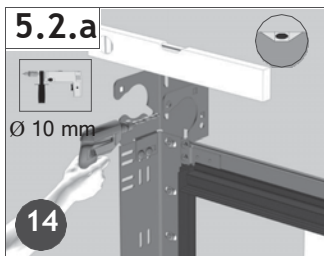

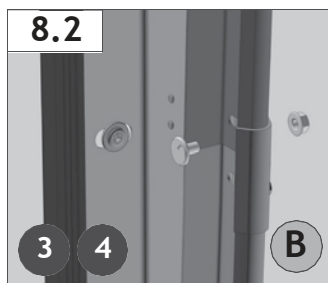
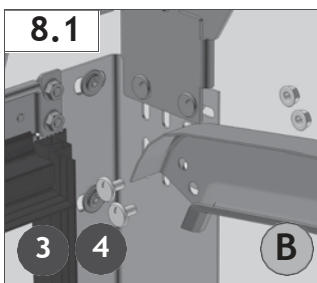
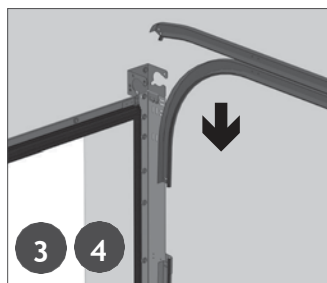
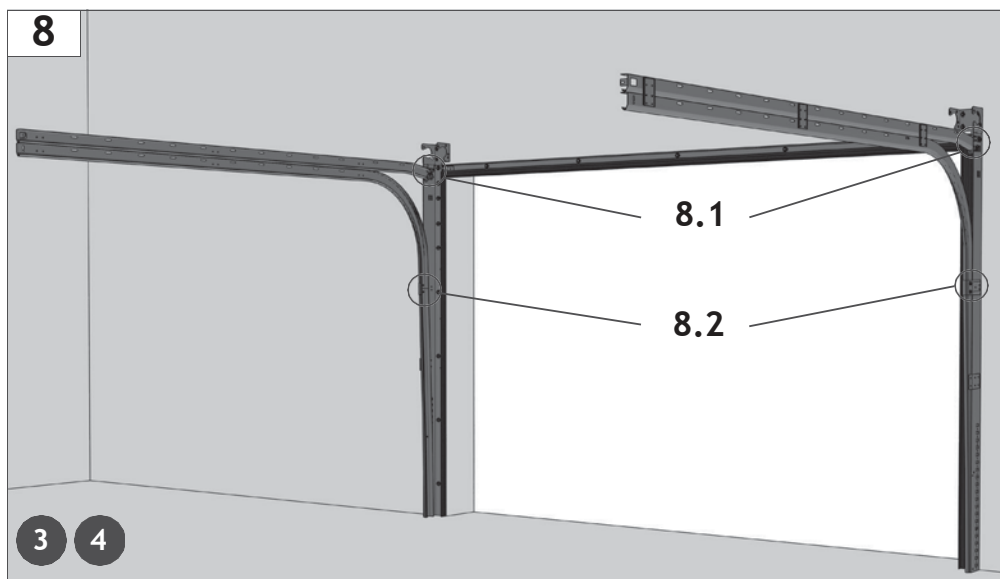
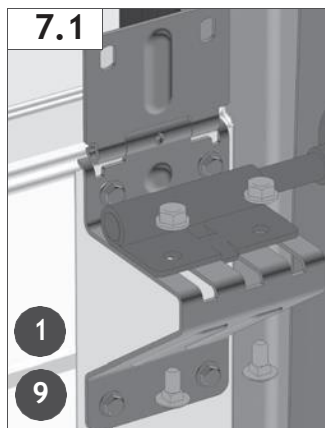
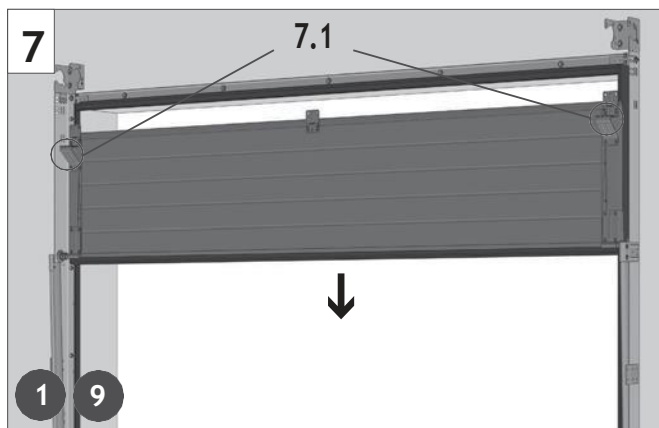

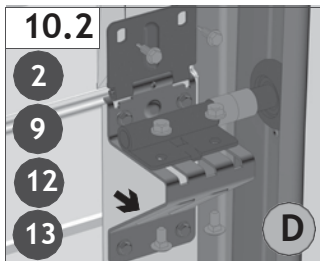
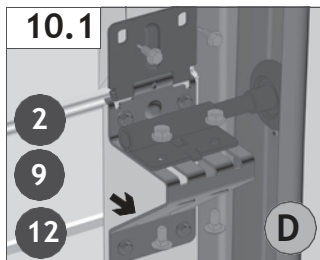
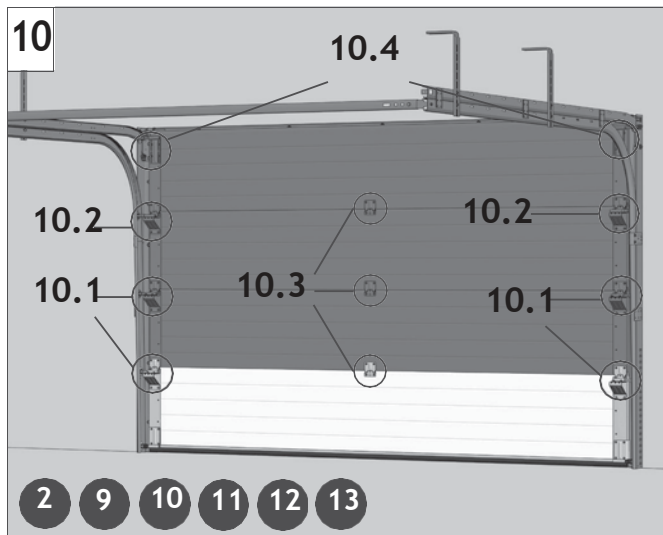
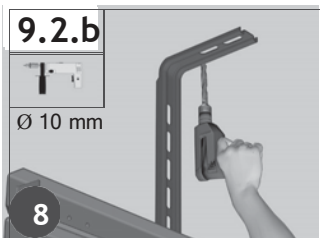
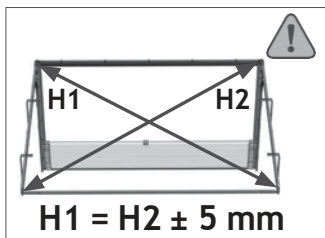
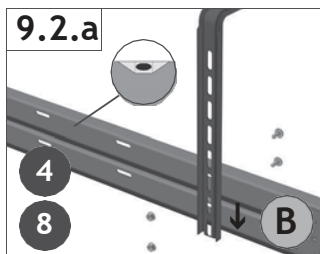
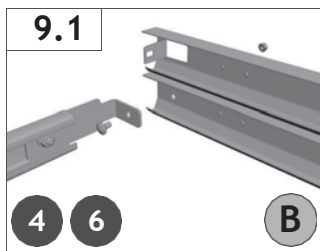
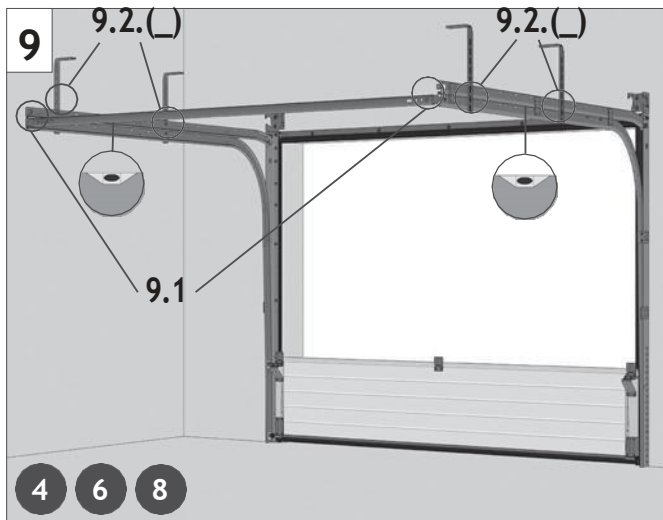

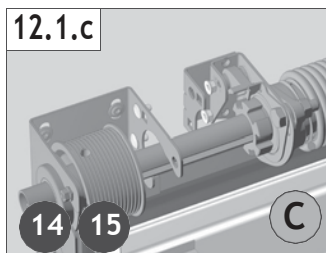
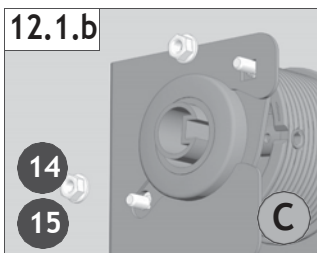
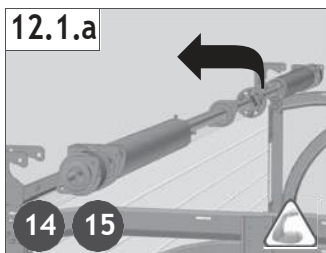
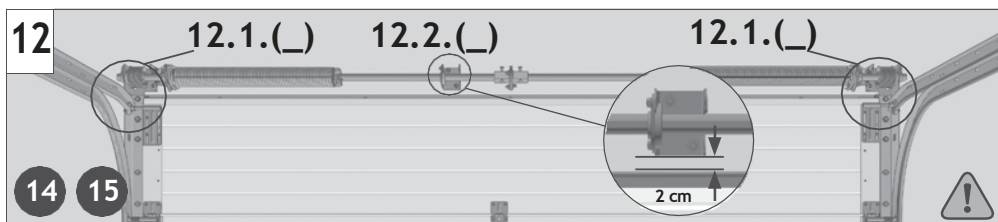
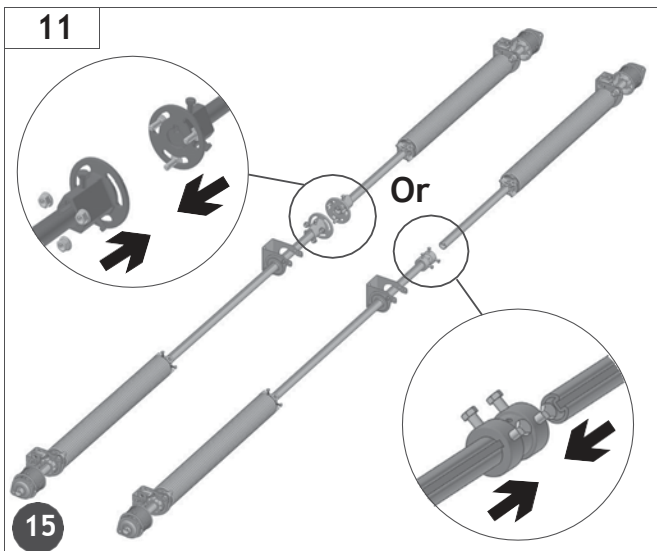
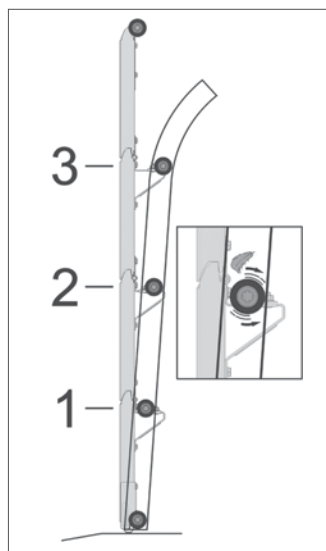
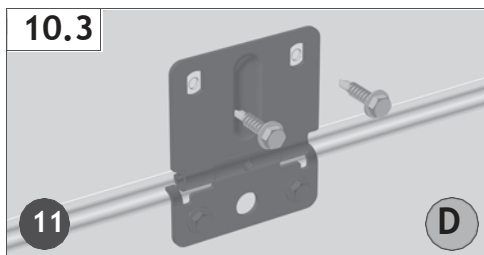

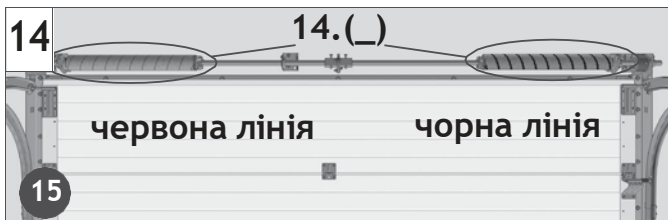
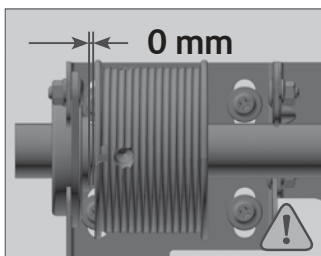
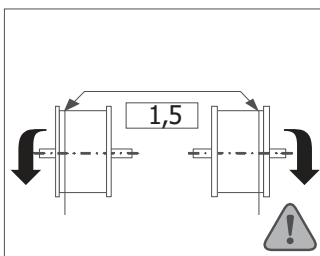
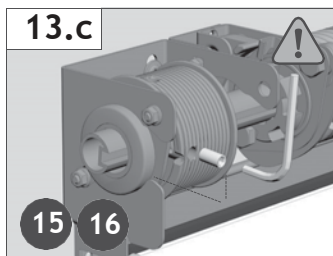
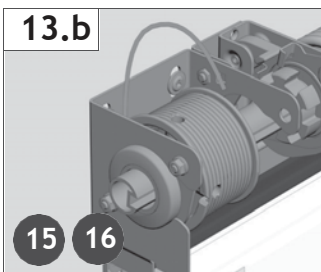
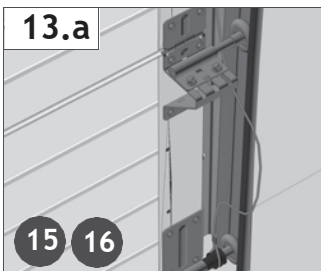
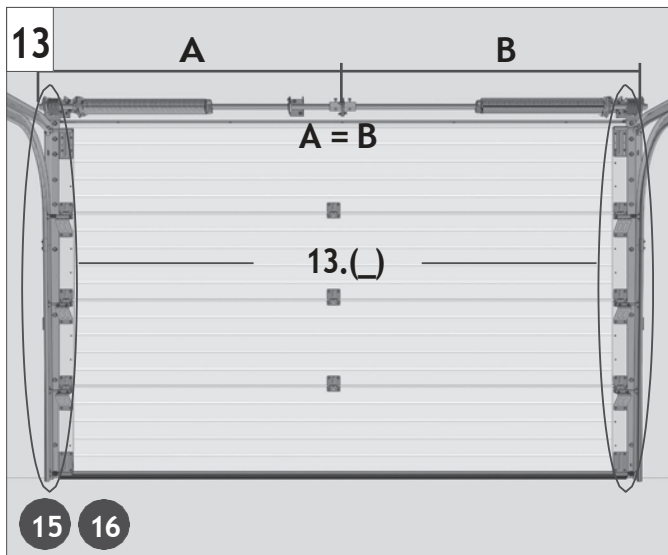
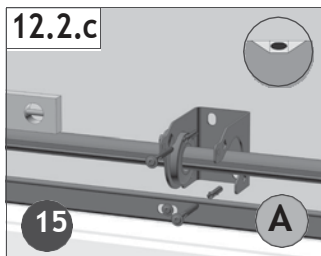
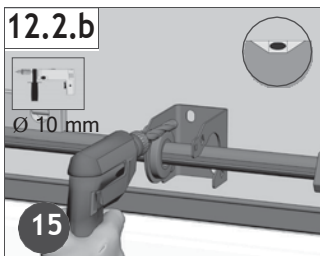
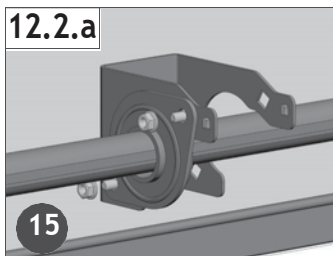

FutureGate					
Serial number: <input type="text"/>					
Order number: <input type="text"/>					
Type:		Lift: SL			
Springs:	N	L	D	d	z
	<input type="text"/>	<input type="text"/>	<input type="text"/>	<input type="text"/>	<input type="text"/>
Weight of door: <input type="text"/>					
Year of production: <input type="text"/>					
Heat conductivity factor: <input type="text"/>					

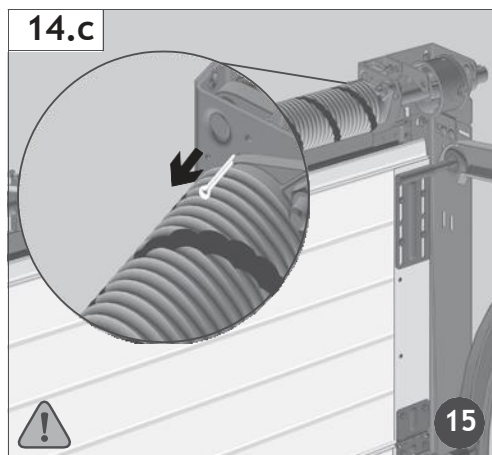
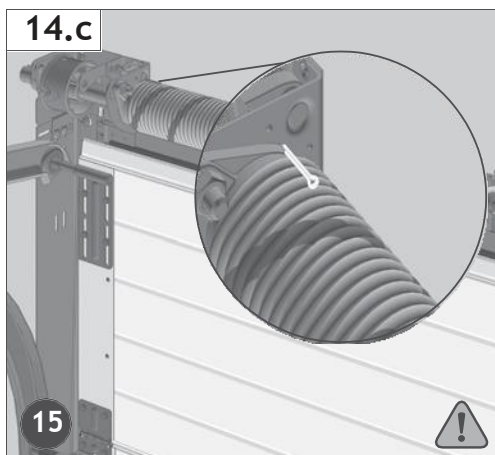
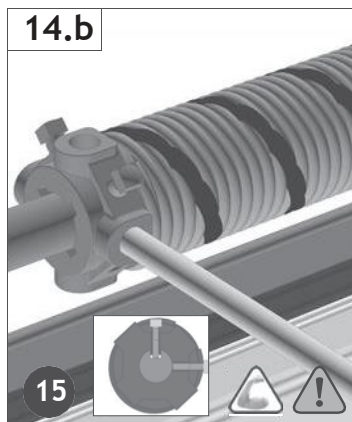
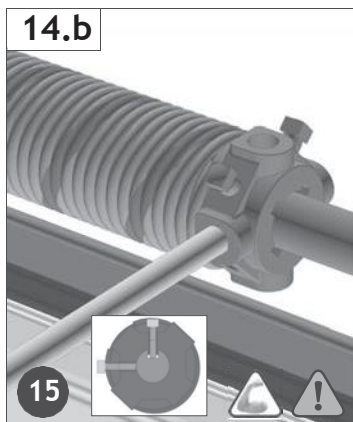
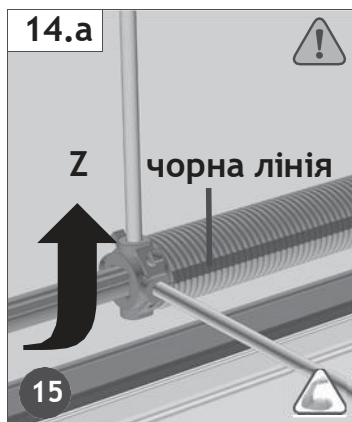
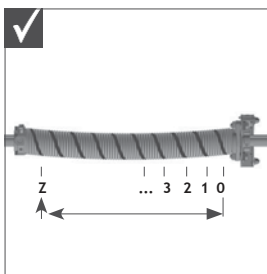
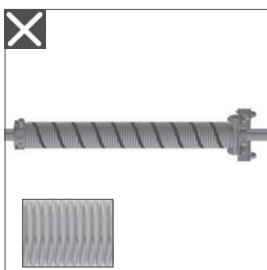

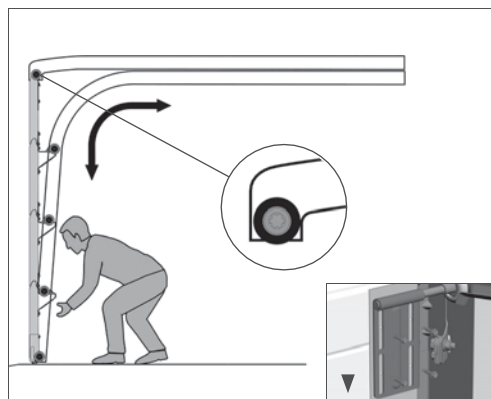
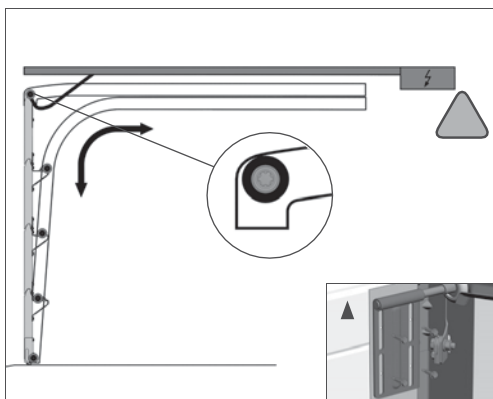
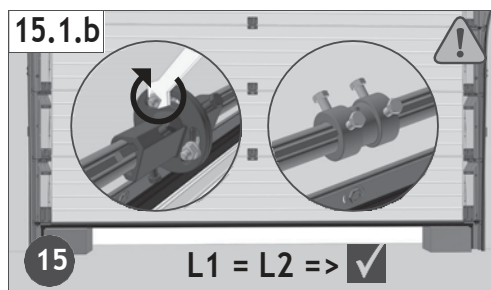
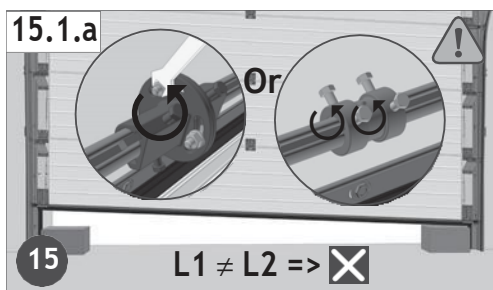
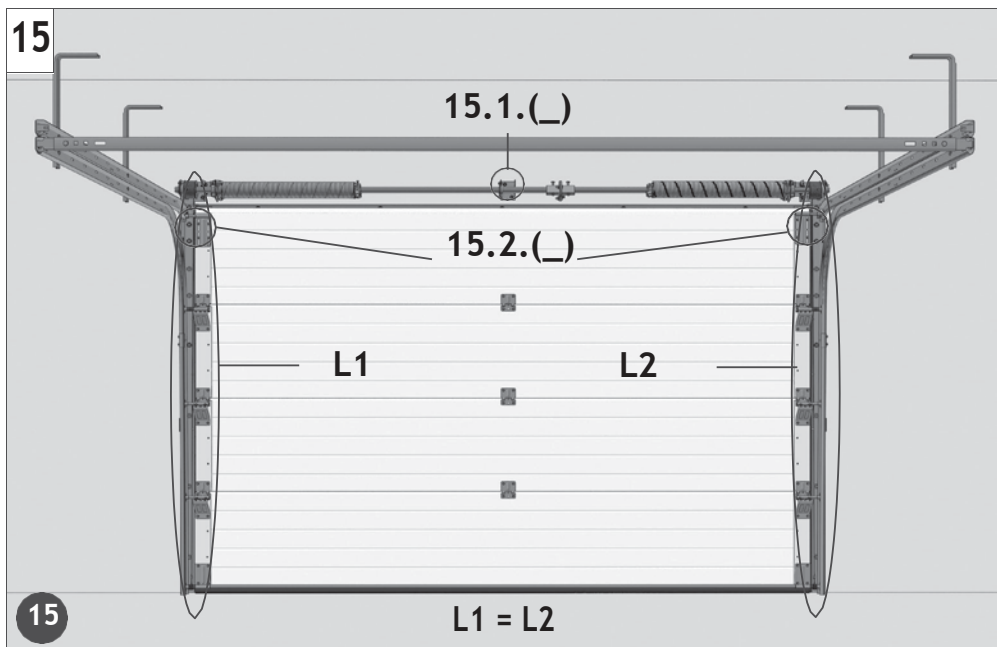

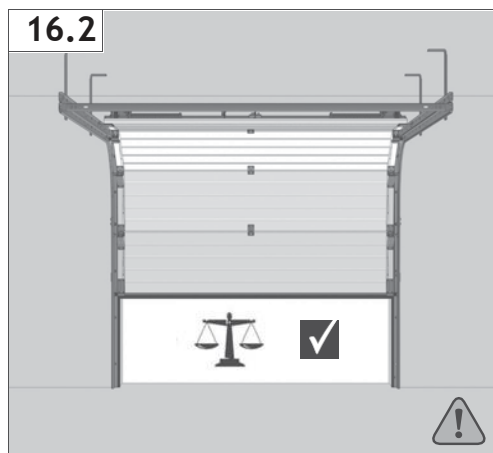
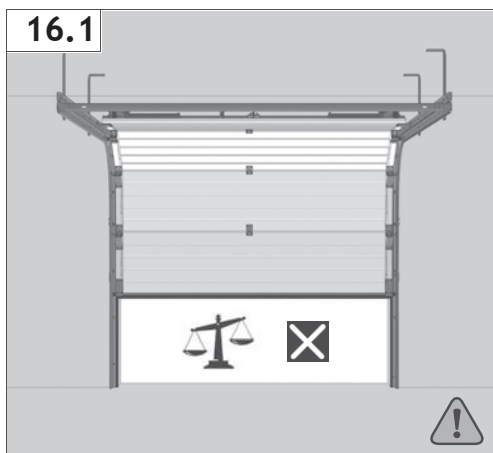
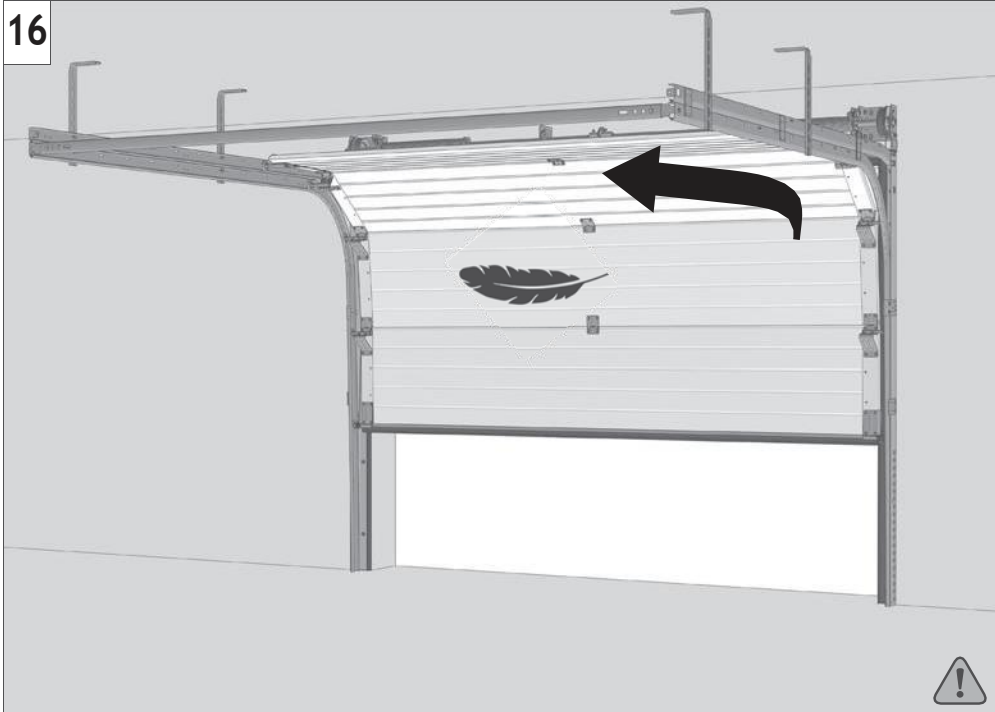



# FuturaGate

[www.futuragate.com](http://www.futuragate.com)